



Configuring the 3G Wireless High-Speed WAN Interface Card for Cisco 1841, and 2800 and 3800 Series Routers (HWIC-3G-GSM)

First Published: March 14, 2007

Revised: July 16, 2007

The Third Generation (3G) Wireless High-Speed WAN Interface Card (HWIC) is a multiband, multiservice WAN card for use over Global System for Mobile Communications/Universal Mobile Telecommunication System (GSM/UMTS) networks. Its primary application is WAN connectivity as a backup data link for critical data applications. However, the 3G wireless HWIC can also function as the primary WAN connection. It is supported on the following Cisco integrated services routers (Cisco ISRs):

- Cisco 1841
- Cisco 2800 series
- Cisco 3800 series

The 3G wireless HWIC provides the following functionality:

- Broadband WAN connectivity using high-speed cellular data technology
- Support for the following technologies:
 - High-speed Downlink Packet Access (HSDPA)
 - Universal Mobile Telecommunication System (UMTS)
 - Enhanced Data-Rates for GSM Evolution (EDGE)
 - General Packet Radio Service (GPRS)



- Automatic best-network selection
- Multiple external antenna options
- Static and dynamic IP addressing
- Modem-based support for mobile IP
- Cellular interface based on the asynchronous interface in Cisco IOS software
- Network Address Translation (NAT) support
- Security features such as firewall, intrusion-detection systems (IDS), intrusion-prevention systems (IPS), and IPSec VPN on the router
- WAN switchover using Cisco IOS software backup interface feature

Table 1 shows the SKU and the frequencies supported by the 3G wireless HWICs.

Table 1 *SKU Description and Supported Frequencies*

SKU Number	Description	Region	Frequency Bands
HWIC-3G-GSM	HSDPA/UMTS/EDGE/GPRS	Worldwide	850/900/1800/1900 /2100 MHz

Figure 1 shows the GSM (UMTS/HSDPA) HWIC.

Figure 1 *Front Panel of HWIC-3G-GSM*

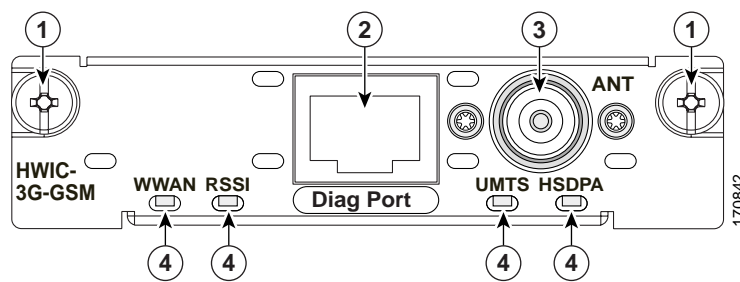

1	Mounting Screws	3	Antenna Connector
2	Diagnostic Port	4	LEDs



Note

The diagnostic port is not required for normal activation or operation. Please see the [“Modem Troubleshooting Using the Diagnostic Port”](#) section on page 73 for details.

Table 2 lists the LEDs and describes their functionality and different states. The LEDs provide a visual indication of your available services. Please see Chapter 13 in the [Cisco Interface Cards Hardware Installation Guide](#) for details on hardware installation.

Table 2 3G Wireless HWIC (GSM) LED Descriptions

LED	Description
RSSI	Off: Low RSSI (under -100 dBm).
	Slow Green Blink: Low or medium RSSI (-99 to -90 dBm).
	Fast Green Blink: Medium RSSI (-89 to -70 dBm).
	Solid Green: High RSSI (-69 dBm or higher).
	Solid Yellow: No service or no RSSI detected.
WWAN	Off: HWIC in reset mode or not powered.
	Slow blink: Searching for service.
	Solid Green: Active service; no traffic detected.
	Fast Blink: Active service, and traffic detected proportional to blink rate.
UMTS	UMTS is the active service.
HSDPA	HSDPA is the active service.



Note Both UMTS and HSDPA Off: Fallback (EGDE or GPRS) service is active. If the RSSI LED is solid yellow, it means that no service and no RSSI are detected.



Note Active service means the currently available service. Your 3G wireless HWIC automatically selects the best available connection.

The 3G wireless HWIC provides the following software functionality:

- Modem activation—You can activate the modem by using Cisco IOS commands.
- Modem management—You can access modem software and hardware information, radio and network status, and data profile information by using Cisco IOS commands.
- Dial on Demand Routing (DDR)—This allows you to set up a data call when there is data traffic to be sent over the wireless network.
- Fallback connection (DDR backup)—The 3G wireless WAN HWIC allows you to configure the cellular modem to initiate a dialup connection when connection to a primary service is lost.
- Teardown after fallback (part of fallback DDR)—After a primary connection has failed and the cellular connection is in fallback mode, the 3G wireless HWIC tears down the fallback-mode connection when the primary connection is available.
- Automatic teardown—After a configurable timeout, the 3G wireless HWIC automatically tears down a connection if there has been no activity.
- Portable application—You can move the router into different coverage areas (different base stations within the same service provider) and the router establishes a connection with the nearest cell infrastructure automatically. This is different from the mobile capability that cell phones offer.
- Autodetect—The 3G wireless HWIC automatically detects and uses the best available service.
- Firmware upgrade—You can upgrade the firmware on the modem by using Cisco IOS commands.

Feature History

Release	Modification
12.4(11)XV	This feature was introduced.

Finding Support Information for Platforms and Cisco IOS Software Images

Use Cisco Feature Navigator to find information about platform support and Cisco IOS software image support. Access Cisco Feature Navigator at <http://www.cisco.com/go/fn>. You must have an account on Cisco.com. If you do not have an account or have forgotten your username or password, click **Cancel** at the login dialog box and follow the instructions that appear.

Contents

- [Prerequisites for Configuring the 3G Wireless HWIC, page 4](#)
- [Restrictions for Configuring the 3G Wireless HWIC, page 5](#)
- [Overview of GSM/UMTS Data Network, page 5](#)
- [How to Configure the 3G Wireless HWIC \(HWIC-3G-GSM\), page 9](#)
- [Configuration Examples for the Wireless HWIC, page 18](#)
- [Modem Firmware Upgrade, page 23](#)
- [Additional References, page 25](#)
- [Command Reference, page 26](#)
- [Troubleshooting, page 69](#)

Prerequisites for Configuring the 3G Wireless HWIC

The following are prerequisites to configuring the wireless HWICs:

- You must have service availability on the HWIC from a carrier, and you must have network coverage where your router will be physically placed. For a complete list of supported carriers, see the data sheet at the following URL: <http://www.cisco.com/go/3g>
- You must subscribe to a service plan with a wireless service provider and obtain a SIM card from the service provider.
- You must install the SIM card before configuring the 3G Wireless HWIC. For instructions on how to install the SIM card, see Chapter 13 in the *Cisco Interface Cards Hardware Installation Guide* at the following URL:
http://cisco.com/en/US/products/hw/modules/ps2641/products_module_installation_guide_book09186a0080692b21.html
- You must install the required antennas before you configure the 3G HWIC. See the following URLs for instructions on how to install the antennas:
 - 3G-ANTM1919D—See the *Cisco Multiband Swivel Mount Dipole Antenna (3G-ANTM1919D)*
 - 3G-ANTM1916-CM—See the *Cisco Multiband Omnidirectional Ceiling Mount Antenna (3G-ANTM1916-CM)*
 - 3G-AE015-R (Antenna Extension)—See the *Cisco Single-Port Antenna Stand for Multiband TNC Male-Terminated Portable Antenna (3G-AE015-R)*

- You must check your LEDs for signal reception as described in [Table 2](#).
- You should be familiar with the Cisco IOS software, beginning with Release 12.4(11)XV or later for Cisco HWIC support. (See the Cisco IOS documentation.)
- To configure your GSM data profile, you will need the following information from your service provider:
 - Username
 - Password
 - Access Point Name (APN)

Restrictions for Configuring the 3G Wireless HWIC

The following restrictions apply to configuring the Cisco Wireless HWICs:

- Data connection can be originated only by the 3G wireless HWIC. Remote dial-in is not supported.
- Throughput—due to the shared nature of wireless communications, the experienced throughput varies depending on the number of active users or congestion in a given network.
- Cellular networks have higher latency compared to wired networks. Latency rates depend on the technology and carrier. Latency may be higher because of network congestion.
- Only one 3G wireless WAN HWIC is supported in the router at a time. Multiple cellular on a single chassis is not a supported configuration at this time.
- VoIP is not currently supported.
- Any restrictions that are a part of the terms of service from your carrier.

Overview of GSM/UMTS Data Network

The Global System for Mobile Communications (GSM) is the most widely deployed cellular network in the world. It is based on the specification from European Telecommunications Standards Institute (ETSI). GSM was primarily designed for voice and was circuit switched but due to the popularity of cellular networks and the great demand for data services, GPRS was introduced as a packet switched data overlay over the GSM radio network. The radio and network resources of GPRS are accessed only when data actually needs to be transmitted between the GPRS mobile user and the GPRS network.

GPRS introduced several new network nodes into the GSM architecture for packet switching, they form the Mobile Packet Core. The Mobile Packet Core includes the Serving GPRS Support Node (SGSN) and the GPRS Gateway Support Node (GGSN). The SGSN is the node which in some ways carries out the same function as the Foreign Agent in Mobile IP. It tunnels IP packets towards the GGSN and detunnels packets back from the GGSN. It also carries out mobility managed and billing. The GGSN is the node which carries out the role in GPRS equivalent to the Home Agent in Mobile IP. The GGSN provides the connectivity to the IP network and the SGSN. It is responsible for IP address assignment and is the default router for the connected User Equipment (UE).

[Figure 2](#) shows a GSM network and the network elements it contains.

Figure 2 GSM Network Overview

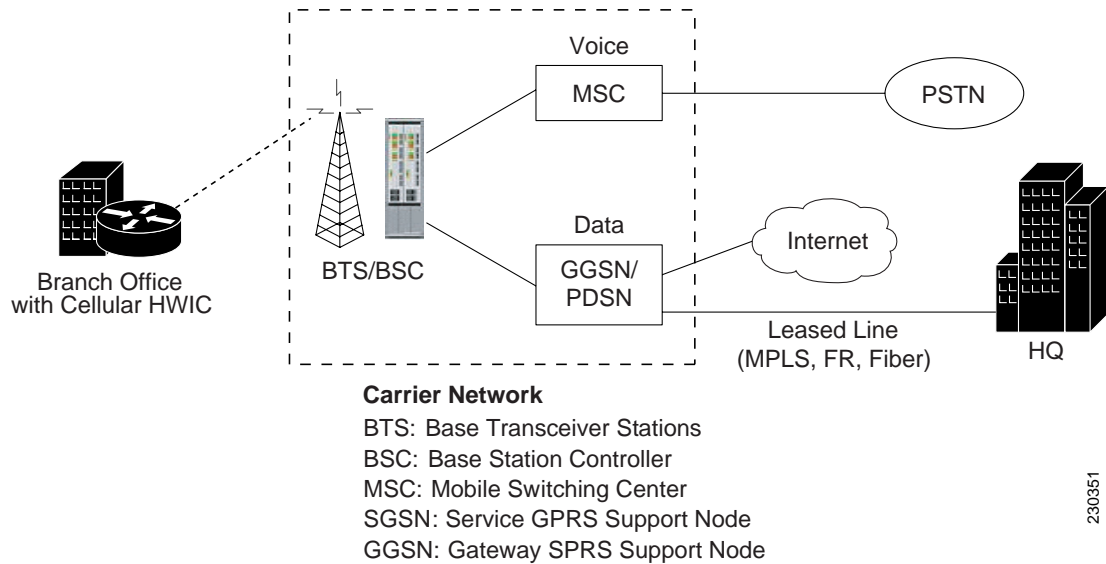

230351

The Base Transceiver Station (BTS) and Base Station Controller (BSC) are located at the Cell site and are the common nodes for both voice and data services. They provide the radio or the physical layer connectivity between the mobile user and the mobile network. As the BSC voice and data traffic get segregated, the voice traffic goes to the Mobile Switching Center (MSC), while the data traffic is sent to the GGSN. From the GGSN, the data packets either go directly to the internet or they can be backhauled to the customer data center for a VPN connection.

UMTS is a 3G wireless system that delivers high-bandwidth data and voice services to mobile users. UMTS evolved from GSM. UMTS has a new air interface based on Wideband Code Division Multiple Access (W-CDMA) and an IP core network based on general-packet radio service (GPRS). The nodes in a UMTS network are almost the same as in a GSM/GPRS network. BTS and BSC have been renamed to Node B and Radio Network Controller (RNC), respectively. UMTS addresses the growing demand of mobile and Internet applications for new capacity in the overcrowded mobile communications sky. The new network increases transmission speed to 2 Mbps per mobile user and establishes a global roaming standard.

Supported Cisco Antennas and Cables

Table 3 lists the Cisco antennas that are supported for use on the 3G wireless HWIC.

Table 3 Cisco Antennas Supported on the 3G Wireless HWIC

Cisco Part Number	Antenna Type	Maximum Gain and Frequency Range	Description
3G-ANTM1919D	Dipole Omnidirectional	0 dBi (806–960 MHz) 0 dBi (1710–2170 MHz)	This is the default antenna. Multiband faceplate-mounted dipole antenna. For more information, see the Cisco Multiband Swivel Mount Dipole Antenna (3G-ANTM1919D) document.
3G-ANTM1916-CM	High-Gain Ceiling-Mount Omnidirectional	1.5 dBi (806–960 MHz) 2.5 dBi (1710–2170 MHz)	Multiband ceiling-mounted omnidirectional antenna. For more information, see the Cisco Multiband Omnidirectional Ceiling Mount Antenna (3G-ANTM1916-CM) document.
3G-AE015-R (Antenna Extension)	Extension Base	0.8–6.0 GHz	This antenna extension is a base with a 15-foot cable included for use with a dipole omnidirectional antenna. For more information, see the Cisco Single-Port Antenna Stand for Multiband TNC Male-Terminated Portable Antenna (3G-AE015-R) document.

Table 4 lists insertion loss information for the ultra-low-loss (ULL) LMR 400 extension cables available from Cisco for use with the ceiling-mounted antenna.

Table 4 Cisco Extension Cables for Use with Antennas

Cisco Product Number	Cable Length	Insertion Loss	Frequency (MHz)
3G-CAB-ULL-20	20 ft (6 m)	1.50 dB max.	2100
3G-CAB-ULL-50	50 ft (15 m)	3.50 dB max.	2100

[Figure 3](#) shows the various antenna options for the 3G wireless HWIC.

Figure 3 Antenna Options

How to Configure the 3G Wireless HWIC (HWIC-3G-GSM)

To configure the 3G wireless HWIC, follow these procedures:

- [Data Account Provisioning](#)
- [Data Call Setup](#)

Data Account Provisioning



Note

To provision your modem, you must have an active wireless account with a service provider and a SIM card installed in your 3G wireless HWIC.

To provision your data account, follow these procedures:

- [Verifying Signal Strength and Service Availability, page 9](#)
- [Configuring a Modem Data Profile, page 10](#)

Verifying Signal Strength and Service Availability

To verify the signal strength and service availability on your modem, use the following commands in privileged EXEC mode.

SUMMARY STEPS

1. **show cellular network**
2. **show cellular radio**
3. **show cellular profile**
4. **show cellular security**
5. **show cellular all**

DETAILED STEPS

	Command or Action	Purpose
Step 1	Router# show cellular <slot/wic/port> network Example: Router# show cellular 0/0/0 network	Displays information about the carrier network, cell site, and available service.
Step 2	Router# show cellular <slot/wic/port> radio Example: Router# show cellular 0/0/0 radio	Shows the radio signal strength.  Note The RSSI should be better than -90 dBm for steady and reliable connection.
Step 3	Router# show cellular <slot/wic/port> profile Example: Router# show cellular 0/0/0 profile	Shows information about the modem data profiles created.
Step 4	Router# show cellular <slot/wic/port> security Example: Router# show cellular 0/0/0 security	Shows the security information for the modem, such as SIM and modem lock status.
Step 5	Router# show cellular <slot/wic/port> all Example: Router# show cellular 0/0/0 all	Shows consolidated information about the modem, profiles created, radio signal strength, network security, and so on.

Configuring a Modem Data Profile

To configure or create a new modem data profile, enter the following command in privileged EXEC mode.

SUMMARY STEPS

1. **cellular gsm profile create** <profile number> <apn> <authentication> <username> <password>

DETAILED STEPS

Command or Action	Purpose
Router# cellular <slot/wic/port> gsm profile create <profile number> <apn> <authentication> <username> <password> Example: Router# cellular 0/0/0 gsm profile create 3 apn.com chap GSM GSMPassword	Creates a new modem data profile. Refer to Table 5 for details on the command parameters.

Table 5 Modem Data Profile Parameters

<i>profile number</i>	Number for the profile you are creating. You can create upto 16 profiles.
<i>apn</i>	Access Point Name. You must get this information from the service provider.
<i>authentication</i>	The type of authentication. For example, CHAP, PAP.
<i>Username</i>	The username provided by your service provider.
<i>Password</i>	The password provided by your service provider.

Data Call Setup

To set up a data call, use the following procedures:

- [Configuring the Cellular Interface, page 11](#)
- [Configuring DDR, page 13](#)
- [Configuring DDR Backup, page 15](#)

Figure 4 shows a typical data call setup with the 3G wireless HWIC.

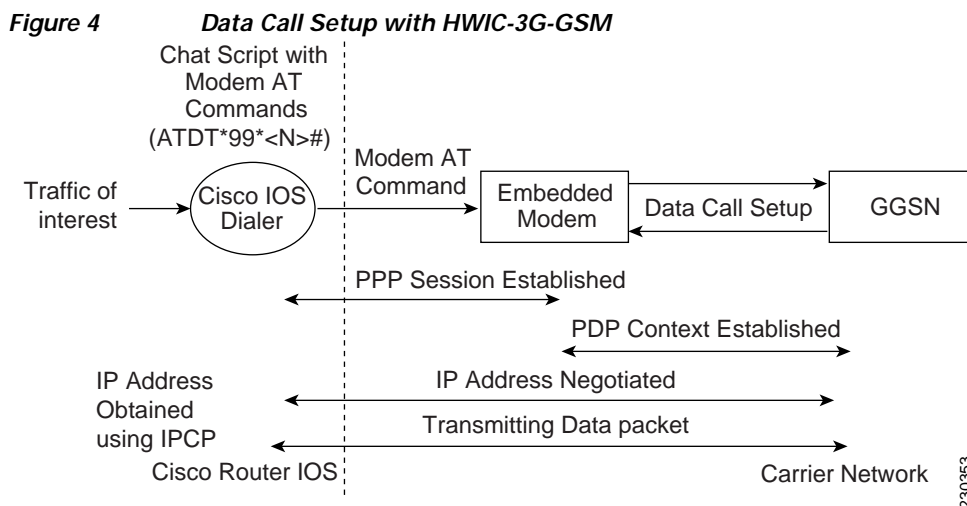

Configuring the Cellular Interface

To configure the cellular interface, enter the following commands in the cellular interface mode.

SUMMARY STEPS

1. **configure terminal**
2. **interface cellular** <slot/wic/port>
3. **encapsulation ppp**
4. **ppp chap hostname** <host>
5. **ppp chap password 0** <password>
6. **asynchronous mode interactive**

7. ip address negotiated



Note

The PPP CHAP authentication parameters that you use in this procedure must be the same as the username and password provided by your carrier and configured under the GSM profile.

DETAILED STEPS

	Command or Action	Purpose
Step 1	Router# configure terminal Example: Router# configure terminal	Enters global configuration mode from the terminal.
Step 2	Router(config)# interface cellular <slot/wic/port> Example: Router (config)# interface cellular 0/0/0	Specifies the cellular interface.
Step 3	Router(config-if)# encapsulation ppp Example: Router (config-if)# encapsulation ppp	Specifies PPP encapsulation for an interface configured for dedicated asynchronous mode or dial-on-demand routing (DDR).
Step 4	Router(config-if)# ppp chap hostname <hostname> Example: Router (config-if)# ppp chap hostname cisco@wwan.ccs	Defines an interface-specific CHAP hostname. This must match the username given by the carrier.
Step 5	Router(config-if)# ppp chap password <password> Example: Router (config-if)# ppp chap password 0 cisco	Defines an interface-specific CHAP password. This must match the password given by the carrier.
Step 6	Router(config-if)# async mode interactive Example: Router (config-if)# async mode interactive	Returns a line that has been placed into dedicated asynchronous network mode to interactive mode, thereby enabling the SLIP and PPP commands in privileged EXEC mode.
Step 7	Router(config-if)# ip address negotiated Example: Router (config-if)# ip address negotiated	Specifies that the IP address for a particular interface is obtained via PPP/PCP address negotiation.



Note

When a static IP address is required for the cellular interface, the address may be configured as **ip address negotiated**. During IPCP, the network ensures that the correct static IP address is allocated to the device. If a tunnel interface is configured with **ip address unnumbered** <cellular interface>, it is necessary to configure the actual static IP address under the cellular interface, in place of **ip address negotiated**. For a sample cellular interface configuration, see the “[Basic Cellular Interface Configuration](#)” section on page 18.

Configuring DDR

To configure DDR for the cellular interface, follow these steps.

SUMMARY STEPS

1. **configure terminal**
2. **interface cellular** *<slot/wic/port>*
3. **dialer in-band**
4. **dialer idle-timeout** *<seconds>*
5. **dialer string** *<string>*
6. **dialer group** *<number>*
7. **exit**
8. **dialer-list** *<dialer-group>* **protocol** *<protocol-name>* { **permit** | **deny** | **list** *<access-list-number>* | **access-group** }>
9. **ip access-list***<access list number>***permit** *<ip source address>*
10. **line** *<slot/wic/port>*
11. **script dialer** *<regex>*
12. **exit**
13. **chat-script** *<script name>* **"" "ATDT*99**<profile number>*#"** **TIMEOUT** *<timeout value>*
CONNECT
14. **interface cellular** *<slot/wic/port>*
15. **dialer string** *<string>*

DETAILED STEPS

	Command or Action	Purpose
Step 1	Router# configure terminal Example: Router# configure terminal	Enters global configuration mode from the terminal.
Step 2	Router(config)# interface cellular <i><slot/wic/port></i> Example: Router (config)# interface cellular 0/0/0	Specifies the cellular interface.
Step 3	Router(config-if)# dialer in-band Example: Router (config-if)# dialer in-band	Enables DDR and configures the specified serial interface to use in-band dialing.

	Command or Action	Purpose
Step 4	<pre>Router(config-if)# dialer idle-timeout <seconds></pre> <p>Example: Router (config-if)# dialer idle-timeout 30</p>	Specifies the duration of idle time, in seconds, after which a line will be disconnected.
Step 5	<pre>Router(config-if)# dialer string <string></pre> <p>Example: Router (config-if)# dialer string gsm</p>	Specifies the number or string to dial. Use the name of the CHAT script here.
Step 6	<pre>Router(config-if)# dialer-group <number></pre> <p>Example: Router (config-if)# dialer-group 1</p>	Specifies the number of the dialer access group to which the specific interface belongs.
Step 7	<pre>Router(config-if)# exit</pre> <p>Example: Router (config-if)# exit</p>	Enters the global configuration mode.
Step 8	<pre>Router(config)# dialer-list <dialer-group> protocol <protocol-name> {permit deny list <access-list-number> access-group}></pre> <p>Example: Router (config)# dialer-list 1 protocol ip list 1</p>	Creates a dialer list for traffic of interest and permits access to an entire protocol.
Step 9	<pre>Router(config)# ip access-list<access list number>permit <ip source address></pre> <p>Example: Router (config)# ip access list 1 permit any</p>	Defines traffic of interest.
Step 10	<pre>Router(config)# line <slot/wic/port></pre> <p>Example: Router (config-line)# line 0/0/0</p>	Specifies the line configuration mode.
Step 11	<pre>Router(config-line)script dialer <regexp></pre> <p>Example: Router (config-line)# script-dialer gsm</p>	Specifies a default modem chat script.
Step 12	<pre>Router(config-line)exit</pre> <p>Example: Router (config-line)# exit</p>	Exits line configuration mode.
Step 13	<pre>Router(config)# chat-script <script name> "" "ATDT*99*<profile number>#" TIMEOUT <timeout value> CONNECT</pre> <p>Example: Router (config)# chat-script gsm "" "ATDT*98*2#" TIMEOUT 60 "CONNECT"</p>	Defines the ATDT commands when the dialer is initiated.

	Command or Action	Purpose
Step 14	<pre>Router(config)# interface cellular <slot/wic/port></pre> <p>Example: <pre>Router (config)# interface cellular 0/1/0</pre></p>	Specifies the cellular interface.
Step 15	<pre>Router(config-if)# dialer string <string></pre> <p>Example: <pre>Router (config)# dialer string gsm</pre></p>	Specifies the dialer script (defined using the chat script command).

Configuring DDR Backup

To monitor the primary connection and initiate the backup connection when needed, the router can use one of the following methods:

- **Backup Interface**—The backup interface that stays in standby mode until the primary interface line protocol is detected as down and then is brought up.
- **Floating Static Route**—The route through the backup interface has an administrative distance that is greater than the administrative distance of the primary connection route and therefore would not be in the routing table until the primary interface goes down.
- **Dialer Watch**—Dialer watch is a backup feature that integrates dial backup with routing capabilities.

Configuring Interfaces to Use a Backup Interface

To configure one or more interfaces to use a backup interface, use the following commands, beginning in global configuration mode.

SUMMARY STEPS

1. **interface** *type number*
2. **backup interface cellular** *number*
3. **backup delay** *enable-delay disable-delay*

DETAILED STEPS

	Command or Action	Purpose
Step 1	Router(config)# interface type number Example: Router(config)# interface ATM0/0/0	Specifies the interface to be backed up and begins interface configuration mode.
Step 2	Router(config-if)# backup interface cellular <number> Example: Router(config-if)# backup interface cellular0/3/0	Specifies the cellular interface as backup.
Step 3	Router(config-if)# backup delay enable-delay disable-delay Example: Router(config-if)# backup delay enable delay	Specifies delay between the physical interface going down and the backup interface being enabled, and between the physical interface coming back up and the backup being disabled.

**Note**

You cannot configure a backup interface for the cellular interface and any other asynchronous serial interface.

Configuring DDR Backup Using Dialer Watch

To initiate dialer watch, you must configure the interface to perform DDR and backup. Use traditional DDR configuration commands, such as dialer maps, for DDR capabilities. To enable dialer watch on the backup interface and create a dialer list, use the following commands in interface configuration mode.

SUMMARY STEPS

1. **configure terminal**
2. **interface** type number
3. **dialer watch group** group-number
4. **dialer watch-list** group-number **ip** ip-address address-mask
5. **dialer-list** <dialer-group> **protocol** <protocol name> {**permit** | **deny** | **list** <access list number> | **access-group**}
6. **ip access-list** <access list number> **permit** <ip source address>
7. **interface cellular** <slot/wic/port>
8. **dialer string** <string>

DETAILED STEPS

	Command or Action	Purpose
Step 1	Router# configure terminal Example: Router# configure terminal	Enters global configuration mode from the terminal.
Step 2	Router(config)# interface type number Example: Router (config)# interface ATM0/0/0	Specifies the interface.
Step 3	Router(config-if)# dialer watch-group group-number Example: Router(config-if)# dialer watch-group 2	Enables dialer watch on the backup interface.
Step 4	Router(config)# dialer watch-list group-number ip ip-address address-mask Example: Router(config-if)# dialer watch-list 2 ip 10.4.0.254 255.255.0.0	Defines a list of all IP addresses to be watched.
Step 5	Router(config)# dialer-list <dialer-group> protocol <protocol-name> { permit deny list <access-list-number> access-group }> Example: Router(config)# dialer-list 2 protocol ip permit	Creates dialer list for traffic of interest and permits access to an entire protocol.
Step 6	Router(config)# ip access-list <access list number> permit <ip source address> Example: Router(config)# access list 2 permit 10.4.0.0	Defines traffic of interest.  Note Do not use the access list permit all command to avoid sending traffic to the IP network. This may result in call termination.
Step 7	Router(config)# interface cellular <slot/wic/port> Example: Router (config)# interface cellular 0/1/0	Specifies the cellular interface.
Step 8	Router(config-if)# dialer string <string> Example: Router (config)# dialer string cdma	Specifies the dialer script (defined using the chat script command).

Configuring DDR Backup Using Floating Static Route

To configure a floating static default route on the secondary interface beginning in the global configuration mode, perform the following tasks.

**Note**

Make sure you have ip classless enabled on your router.

SUMMARY STEPS

1. **configure terminal**
2. **ip route** *network-number network-mask* {ip address | interface} [administrative distance] [**name name**]

DETAILED STEPS

	Command or Action	Purpose
Step 1	Router# configure terminal Example: Router# configure terminal	Enters global configuration mode from the terminal.
Step 2	Router(config)# ip route network-number network-mask {ip-address interface} [administrative distance] [name name] Example: Router (config)# ip route 0.0.0.0 Dialer 2 track 234	Establishes a floating static route with the configured administrative distance through the specified interface.  Note A higher administrative distance should be configured for the route through the backup interface, so that it is used only when the primary interface is down.

Configuration Examples for the Wireless HWIC

This section provides the following configuration examples:

- [Basic Cellular Interface Configuration, page 18](#)
- [Tunnel over Cellular Interface Configuration, page 19](#)
- [3G Wireless Modem as Backup with NAT and IPSec, page 20](#)

Basic Cellular Interface Configuration

The following example shows how to configure the cellular interface to be used as a primary and is configured as the default route:

```
chat-script gsm "" "ATDT*98*2#" TIMEOUT 60 "CONNECT"

!
interface Cellular0/0/0
```

```

ip address negotiated
encapsulation ppp
dialer in-band
dialer string gsm
dialer-group 1
async mode interactive
ppp chap hostname cisco@wwan.ccs
ppp chap password 0 cisco
ppp ipcp dns request
!

ip route 0.0.0.0 0.0.0.0 Cellular0/0/0
!
!
access-list 1 permit any
dialer-list 1 protocol ip list 1
!
line 0/0/0
exec-timeout 0 0
script dialer gsm
login
modem InOut

```

Tunnel over Cellular Interface Configuration

The following example shows how to configure the static IP address when a tunnel interface is configured with **ip address unnumbered** <cellular interface>:

```

interface Tunnel2
 ip unnumbered Cellular0/3/0
 tunnel source Cellular0/3/0
 tunnel destination 128.107.248.254

interface Cellular0/3/0
 bandwidth receive 1400000
 ip address 23.23.0.1 255.255.0.0
 ip nat outside
 ip virtual-reassembly
 encapsulation ppp
 no ip mroute-cache
 dialer in-band
 dialer idle-timeout 0
 dialer string dial<carrier>
 dialer-group 1
 async mode interactive
 no ppp lcp fast-start
 ppp chap hostname <hostname>
 ppp chap password 0 <password>
 ppp ipcp dns request

! traffic of interest through the tunnel/cellular interface
ip route 10.10.0.0 255.255.0.0 Tunnel2

```

3G Wireless Modem as Backup with NAT and IPSec

The following example shows how to configure the 3G wireless modem on the router as backup with NAT and IPSec:



Note

The receive and transmit speeds cannot be configured. The actual throughput depends on the cellular network service.

```

ip dhcp excluded-address 10.4.0.254
!
ip dhcp pool gsm pool
  network 10.4.0.0 255.255.0.0
  dns-server 66.209.10.201 66.102.163.231
  default-router 10.4.0.254
!
!
chat-script gsm "" "atdt*98*1#" TIMEOUT 30 "CONNECT"

crypto isakmp policy 1
  encr 3des
  authentication pre-share
crypto isakmp key gsm address 128.107.241.234
!
!
crypto ipsec transform-set gsm ah-sha-hmac esp-3des
!
crypto map gsm1 10 ipsec-isakmp
  set peer 128.107.241.234
  set transform-set gsm
  match address 103
!
!
interface ATM0/0/0
  no ip address
  ip virtual-reassembly
  load-interval 30
  no atm ilmi-keepalive
  dsl operating-mode auto
!
interface ATM0/0/0.1 point-to-point
  backup interface Cellular0/3/0
  ip nat outside
  ip virtual-reassembly
  no snmp trap link-status
  pvc 0/35
  pppoe-client dial-pool-number 2
!
!
interface Cellular0/3/0
  bandwidth receive 1400000
  ip address negotiated
  ip nat outside
  ip virtual-reassembly
  encapsulation ppp
  no ip mroute-cache
  dialer in-band
  dialer idle-timeout 0
  dialer string gsm
  dialer-group 1
  async mode interactive

```

```
no ppp lcp fast-start
ppp chap hostname cisco@wan.ccs
ppp chap password 0 cisco
ppp ipcp dns request
crypto map gsml
!

interface Vlan104
description used as default gateway address for DHCP clients
ip address 10.4.0.254 255.255.0.0
ip nat inside
ip virtual-reassembly
!
interface Dialer2
ip address negotiated
ip mtu 1492
ip nat outside
ip virtual-reassembly
encapsulation ppp
load-interval 30
dialer pool 2
dialer-group 2
ppp authentication chap callin
ppp chap hostname cisco@dsl.com
ppp chap password 0 cisco
ppp ipcp dns request
crypto map gsml
!
ip local policy route-map track-primary-if
ip route 0.0.0.0 0.0.0.0 Dialer2 track 234
ip route 0.0.0.0 0.0.0.0 Cellular0/3/0 254
!
!
ip nat inside source route-map nat2cell interface Cellular0/3/0 overload
ip nat inside source route-map nat2dsl interface Dialer2 overload
!
ip sla 1
icmp-echo 209.131.36.158 source-interface Dialer2
timeout 1000
frequency 2
ip sla schedule 1 life forever start-time now
access-list 1 permit any
access-list 2 permit 10.4.0.0 0.0.255.255
access-list 3 permit any
access-list 101 permit ip 10.4.0.0 0.0.255.255 any
access-list 102 permit icmp any host 209.131.36.158
access-list 103 permit ip host 166.138.186.119 128.107.0.0 0.0.255.255
access-list 103 permit ip host 75.40.113.246 128.107.0.0 0.0.255.255
dialer-list 1 protocol ip list 1
dialer-list 2 protocol ip permit
!
!
route-map track-primary-if permit 10
match ip address 102
set interface Dialer2
!
route-map nat2dsl permit 10
match ip address 101
match interface Dialer2
!
route-map nat2cell permit 10
match ip address 101
match interface Cellular0/3/0
!
```

```
line 0/3/0
  exec-timeout 0 0
  script dialer dial gsm
  login
  modem InOut
```

Modem Firmware Upgrade

The 3G Wireless HWIC has an embedded modem from Sierra Wireless (MC8775). The firmware for the modem is upgradable using Cisco IOS commands. The firmware is packaged in a tar distribution file and can be downloaded from the wireless software download page on Cisco.com. Use the following procedure to upgrade the modem firmware:



Caution

Before upgrading the modem to a new firmware version, please check if the new firmware version has been certified by your wireless service provider. Using an uncertified firmware version on the modem may impact the wireless service provider network adversely.

Refer to the following website for the latest certified firmware version for your carrier and IOS compatibility:

http://www.cisco.com/en/US/products/hw/routers/networking_solutions_products_generic_content0900aecd80601f7e.html

SUMMARY STEPS

-
- Step 1 Go to the Cisco Wireless WAN software download website at:
<http://tools.cisco.com/support/downloads/go/Redirect.x?mdfid=278875243>
 - Step 2 Download the appropriate GSM firmware release under Wireless Integrated Switches and Routers.
 - Step 3 Use the archive command to untar the firmware distribution into router flash:
archive tar /xtract source-url destination-url
 - Step 4 Use the following command to initiate the firmware upgrade process:
microcode reload cellular pa-bay slot gsm modem-provision
-

DETAILED STEPS

	Command or Action	Purpose
Step 1	Go to the Cisco Wireless WAN "software download" website at http://tools.cisco.com/support/downloads/go/Redirect.x?mdfid=278875243	Gives you access to Cisco Wireless WAN software downloads. Select firmware for Cisco 3G Wireless HWIC.  Note This Web site is only available to registered Cisco.com users.
Step 2	Download the appropriate GSM firmware release under Wireless Integrated Switches and Routers.	Downloads the modem firmware package to a TFTP/FTP server that is accessible from the router with the 3G Wireless HWIC.

	Command or Action	Purpose
Step 3	<pre>router# archive tar /xtract source-url destination-url</pre> <p>Example: <pre>Router# archive tar /xtract tftp://192.168.1.1/MC8775_1_0_0_7_package.tar flash:</pre></p>	<p>Uncompresses the files of the modem firmware package and copies them to a location that is accessible by the router with the 3G Wireless HWIC.</p> <p><i>source-url</i>—URL of the source location with the firmware TAR filename. Valid URLs can refer to TFTP or HTTP servers or to router flash memory.</p> <p><i>destination-url</i>—URL of the destination where the tar file would be extracted. Use router flash.</p>
Step 4	<pre>router# microcode reload cellular pa-bay slot gsm modem-provision</pre>	<p>Initiates the firmware upgrade process.</p> <p><i>pa-bay</i>—Use 0 for HWIC.</p> <p><i>slot</i>—slot number where the HWIC is plugged in.</p> <p> Note This command requires the cellular interface to be in administrative shutdown mode. The firmware upgrade process may take up to 15 minutes, during which the modem would be inaccessible.</p>

**Caution**

Do not disconnect power or switch the router off during the firmware upgrade process. This may result in permanent modem failure.

Additional References

The following sections provide references related to Configuring the 3G Wireless HWIC.

Related Documents

Related Topic	Document Title
Supported Cisco Antennas	<ul style="list-style-type: none"> • Cisco Multiband Swivel Mount Dipole Antenna (3G-ANTM1919D) • Cisco Multiband Omnidirectional Ceiling Mount Antenna (3G-ANTM1916-CM) • Cisco Single-Port Antenna Stand for Multiband TNC Male-Terminated Portable Antenna (3G-AE015-R)
Hardware Installation	Chapter 13 in the <i>Cisco Interface Cards Hardware Installation Guide</i> , “Connecting 3G Wireless High-Speed WAN Interface Cards to a Network.”

Technical Assistance

Description	Link
The Cisco Technical Support & Documentation website contains thousands of pages of searchable technical content, including links to products, technologies, solutions, technical tips, and tools. Registered Cisco.com users can log in from this page to access even more content.	http://www.cisco.com/techsupport

Command Reference

This section documents new commands only.

- [cellular gsm plmn search](#)
- [cellular gsm plmn select](#)
- [cellular gsm profile create](#)
- [debug cellular driver](#)
- [debug cellular firmware](#)
- [debug cellular messages all](#)
- [debug cellular messages async](#)
- [debug cellular messages data](#)
- [debug cellular messages dm](#)
- [debug cellular messages management](#)
- [debug cellular messages virt-con](#)
- [show cellular all](#)
- [show cellular connection](#)
- [show cellular hardware](#)
- [show cellular network](#)
- [show cellular profile](#)
- [show cellular radio](#)
- [show cellular security](#)
- [show controllers cellular](#)
- [show interfaces cellular](#)
- [show run interface cellular](#)

cellular gsm plmn search

To search for the available public land mobile networks (PLMNs), use the **cellular gsm plmn search** command in privileged EXEC mode.

cellular *slot/wic_slot/port* **gsm plmn search**

Syntax Description	<i>slot/wic_slot/port</i>	Numeric values that indicate the router slot, WAN interface card (WIC) slot, and port.
Command Default	None	
Command Modes	Privileged EXEC	
Command History	Release	Modification
	12.4(11)XV	This command was introduced.
	12.4(15)T	This command was integrated into Cisco IOS Release 12.4(15)T.

Usage Guidelines This command searches for the available PLMNs or carrier networks at your location. After you issue this command, you must wait for the search completion message and then use the **show cellular network** command to view the list of the PLMNs available. It may take up to 5 minutes for the search to be completed.

Examples The following example shows output for this command:

```
router# cellular 0/1/0 gsm plmn search
router#
Dec 12 07:37:15.147: Searching for available PLMNS...Please wait...
Dec 12 07:37:45.095: PLMN search done. Please use "show cellular
x/x/x network" to see available PLMNS
c2800#sh cellular 0/1/0 network
<...deleted...>
Available PLMN's:
PLMN Name = <carrier name>
      MCC = 310, MNC = 380
      Status = Registered,, Network = Unknown
PLMN Name = <carrier name>
      MCC = 310, MNC = 380
      Status = Registered,Supports GPRS, Network = GSM
PLMN Name = <carrier name>
      MCC = 310, MNC = 17
      Status = Supports GPRS, Network = GSM
```

Related Commands

■ cellular gsm plmn search

Command	Description
cellular gsm plmn select	Allows manual or automatic selection of an available PLMN.

cellular gsm plmn select

To manually or automatically select from the available public land mobile network (PLMN) in an area to attach the modem to, use the **cellular gsm plmn select** command in privileged EXEC mode.

```
cellular slot/wic_slot/port gsm plmn select { manual<mcc> <mnc>| auto }
```

Syntax Description	<i>slot/wic_slot/port</i>	Numeric values that indicate the router slot, WAN interface card (WIC) slot, and port.
	manual	Allows manual selection of the PLMN for the modem.
	<i>mcc</i>	Mobile country code—a number between 0 and 65535.
	<i>mnc</i>	Mobile network code—a number between 0 and 65535.
	auto	Automatically selects the PLMN available in the area.

Command Default By default, PLMN is set to automatic.

Command Modes Privileged EXEC

Command History	Release	Modification
	12.4(11)XV	This command was introduced.
	12.4(15)T	This command was integrated into Cisco IOS Release 12.4(15)T.

Examples The following example shows output for the **cellular gsm plmn select manual** command. In this example, the user selects PLMN with MCC=310, MNC=17. The **show cellular x/x/x network**", shows the modem attached to the EDGE network.

```
Dec 12 07:38:43.799: Selecting PLMN mode to Manual...Please wait...
Dec 12 07:38:43.811: PLMN Selection Successful
```

```
router# show cellular 0/1/0 network
Current Service Status = Normal, Service Error = None
Current Service = Combined
Packet Service = EDGE (Attached)
Packet Session Status = Inactive
Current Roaming Status = Roaming
Network Selection Mode = Manual
Country = USA, Network = Cinglr
Mobile Country Code (MCC) = 310
Mobile Network Code (MNC) = 17
Location Area Code (LAC) = 230
Routing Area Code (RAC) = 1
Cell ID = 25573
Primary Scrambling Code = 0
PLMN Selection = Manual
Registered PLMN = Cingular , Abbreviated = Cinglr
Service Provider = ROGERS
```

The following example shows output for the **cellular gsm plmn select auto** command.

```

router# cellular 0/1/0 gsm plmn select auto
router#
Dec 12 07:46:42.751: Selecting PLMN mode to Auto...Please wait...
Dec 12 07:46:42.763: PLMN Selection Successful
router#
router#sh cellular 0/1/0 network
Current Service Status = Normal, Service Error = None
Current Service = Combined
Packet Service = UMTS/WCDMA (Attached)
Packet Session Status = Inactive
Current Roaming Status = Roaming
Network Selection Mode = Automatic
Country = USA, Network = CINGULAR
Mobile Country Code (MCC) = 310
Mobile Network Code (MNC) = 380
Location Area Code (LAC) = 56997
Routing Area Code (RAC) = 253
Cell ID = 4503
Primary Scrambling Code = 169
PLMN Selection = Automatic
Registered PLMN = CINGULAR , Abbreviated = CINGULAR
Service Provider = ROGERS

```

Related Commands

Command	Description
cellular gsm plmn search	Searches for and selects an available public land mobile network (PLMN).
cellular gsm profile create	Creates a new GSM profile.
cellular gsm profile delete	Deletes an existing GSM profile.

cellular gsm profile create

To create a new modem data profile, use the **cellular gsm profile create** command in privileged EXEC mode.

```
cellular slot/wic_slot/port gsm profile create <profile
number><apn><authentication><username><password>
```

Syntax Description		
	<i>slot/wic_slot/port</i>	Numeric values that indicate the router slot, WAN interface card (WIC) slot, and port.
	<i>profile number</i>	Number for the profile you are creating. You can create up to 16 profiles.
	<i>apn</i>	Access point name. You must get this information from the service provider.
	<i>authentication</i>	The type of authentication. For example, CHAP or PAP.
	<i>username</i>	The username provided by your service provider.
	<i>password</i>	The password provided by your service provider.

Command Default None

Command Modes Privileged EXEC

Command History	Release	Modification
	12.4(11)XV	This command was introduced.
	12.4(15)T	This command was integrated into Cisco IOS Release 12.4(15)T.

Usage Guidelines Some of the command parameters, such as username, password, and authentication, are optional, and do not need specification. When multiple profiles are created, you can select the profile used to set up the data call by including the profile number in the **ATDT** command (**ATDT*99*<profile number>#**). If you do not include a profile number in the **ATDT** command (**ATDT*99#**), profile 1 is used.

Examples The following example shows output for this command:

```
router# cellular 0/0/0 gsm profile create 3 apn.com chap GSM GSMPassw
```

```
Profile 3 will be created with the following values:
APN = apn.com
Authenticaton = CHAP
Username = GSM
Password = GSMPassw
Are you sure? [confirm]y
Profile 3 written to modem
```

■ cellular gsm profile create

Related Commands	Command	Description
	cellular gsm profile delete	Deletes an existing GSM profile.
	show cellular profile	Displays the modem data profiles created.

cellular gsm profile delete

To delete a modem data profile you have created, use the **cellular gsm profile delete** command in privileged EXEC mode.

```
cellular slot/wic_slot/port gsm profile delete<profile number>
```

Syntax Description	<i>slot/wic_slot/port</i>	Numeric values that indicate the router slot, WAN interface card (WIC) slot, and port.
	<i>profile number</i>	Number for the profile you are creating.

Command Default None

Command Modes Privileged EXEC

Command History	Release	Modification
	12.4(11)XV	This command was introduced.
	12.4(15)T	This command was integrated into Cisco IOS Release 12.4(15)T.

Usage Guidelines At the command prompt, enter **y** to delete the profile.

Examples The following example shows output from this command:

```
router# cellular 0/0/0 gsm profile delete 3

Profile 3 will be deleted
Are you sure? [confirm]y
Profile 3 deleted from modem
```

Related Commands	Command	Description
	show cellular profile	Displays the modem data profiles created.
	cellular gsm profile create	Creates a new GSM profile.

debug cellular driver

To debug the Cisco IOS driver for the cellular interface, use the **debug cellular driver** command in EXEC mode.

```
debug cellular slot/wic_slot/port driver { crdump | errdump | errors }
```

Syntax Description	<i>slot/wic_slot/port</i>	Numeric values that indicate the router slot, WAN interface card (WIC) slot, and port.
	crdump	CRC error details.
	errdump	Other error details.
	errors	Errors debugging.

Command Default None

Command Modes EXEC

Command History	Release	Modification
	12.4(11)XV	This command was introduced.
	12.4(15)T	This command was integrated into Cisco IOS Release 12.4(15)T.

Usage Guidelines Use this command for debugging purposes only.

Related Commands	Command	Description
	debug cellular messages async	Debugs cellular async.
	debug cellular messages data	Prints Cisco IOS data path debug messages.
	debug cellular firmware	Displays Cisco IOS firmware information.
	debug cellular messages management	Prints management path messages, such as CnS.
	debug cellular messages dm	Prints diagnostics monitor (DM) messages from the Qualcomm CDMA chipset.
	debug cellular messages virt-con	Redirects the Nios II console driver messages to display them in the Cisco IOS router console environment.

debug cellular firmware

To see the Cisco IOS firmware information, use the **debug cellular firmware** command in EXEC mode.

debug cellular *slot/wic_slot/port* **firmware**

Syntax Description	<i>slot/wic_slot/port</i>	Numeric values that indicate the router slot, WAN interface card (WIC) slot, and port.
---------------------------	---------------------------	--

Command Default	None
------------------------	------

Command Modes	EXEC
----------------------	------

Command History	Release	Modification
	12.4(11)XV	This command was introduced.
	12.4(15)T	This command was integrated into Cisco IOS Release 12.4(15)T.

Usage Guidelines	Use this command for debugging purposes only.
-------------------------	---

Related Commands	Command	Description
	debug cellular messages async	Debugs cellular async.
	debug cellular messages data	Prints Cisco IOS data path debug messages.
	debug cellular driver	Debugs the Cisco IOS driver.
	debug cellular messages management	Prints management path messages, such as CnS.
	debug cellular messages dm	Prints diagnostics monitor (DM) messages from the Qualcomm CDMA chipset.
	debug cellular messages virt-con	Redirects the Nios II console driver messages to display them in the Cisco IOS router console environment.

debug cellular messages all

To print all Cisco IOS driver debug messages, use the **debug cellular messages all** command in EXEC mode.

debug cellular *slot/wic_slot/port* **messages all**

Syntax Description	<i>slot/wic_slot/port</i>	Numeric values that indicate the router slot, WAN interface card (WIC) slot, and port.
---------------------------	---------------------------	--

Command Default	None
------------------------	------

Command Modes	EXEC
----------------------	------

Command History	Release	Modification
	12.4(11)XV	This command was introduced.
12.4(15)T	This command was integrated into Cisco IOS Release 12.4(15)T.	

Usage Guidelines	Use this command for debugging purposes only.
-------------------------	---

Related Commands	Command	Description
		debug cellular messages async
	debug cellular messages data	Prints Cisco IOS data path debug messages.
	debug cellular driver	Debugs the Cisco IOS driver.
	debug cellular firmware	Displays Cisco IOS firmware information.
	debug cellular messages management	Prints management path messages, such as CnS.
	debug cellular messages dm	Prints diagnostics monitor (DM) messages from the Qualcomm CDMA chipset.
	debug cellular messages virt-con	Redirects the Nios II console driver messages to display them in the Cisco IOS router console environment.

debug cellular messages async

To debug cellular async, use the **debug cellular messages async** command in EXEC mode.

debug cellular *slot/wic_slot/port* **messages async**

Syntax Description	<i>slot/wic_slot/port</i>	Numeric values that indicate the router slot, WAN interface card (WIC) slot, and port.
---------------------------	---------------------------	--

Command Default	None
------------------------	------

Command Modes	EXEC
----------------------	------

Command History	Release	Modification
	12.4(11)XV	This command was introduced.
	12.4(15)T	This command was integrated into Cisco IOS Release 12.4(15)T.

Usage Guidelines	Use this command for debugging purposes only.
-------------------------	---

Related Commands	Command	Description
	debug cellular messages all	Prints all Cisco IOS driver debug messages.
	debug cellular messages data	Prints Cisco IOS data path debug messages.
	debug cellular driver	Debugs the Cisco IOS driver.
	debug cellular firmware	Displays Cisco IOS firmware information.
	debug cellular messages management	Prints management path messages, such as CnS.
	debug cellular messages dm	Prints diagnostics monitor (DM) messages from the Qualcomm CDMA chipset.
	debug cellular messages virt-con	Redirects the Nios II console driver messages to display them in the Cisco IOS router console environment.

debug cellular messages data

To print Cisco IOS data path debug messages, use the **debug cellular messages data** command in EXEC mode.

show cellular *slot/wic_slot/port* messages data

Syntax Description	<i>slot/wic_slot/port</i>	Numeric values that indicate the router slot, WAN interface card (WIC) slot, and port.
---------------------------	---------------------------	--

Command Default	None
------------------------	------

Command Modes	EXEC
----------------------	------

Command History	Release	Modification
	12.4(11)XV	This command was introduced.
12.4(15)T	This command was integrated into Cisco IOS Release 12.4(15)T.	

Usage Guidelines	Use this command for debugging purposes only.
-------------------------	---

Related Commands	Command	Description
	debug cellular messages all	Prints all Cisco IOS driver debug messages.
debug cellular messages async	Debugs cellular async.	
debug cellular driver	Debugs the Cisco IOS driver.	
debug cellular firmware	Displays Cisco IOS firmware information.	
debug cellular messages management	Prints management path messages, such as CnS.	
debug cellular messages dm	Prints diagnostics monitor (DM) messages from the Qualcomm CDMA chipset.	
debug cellular messages virt-con	Redirects the Nios II console driver messages to display them in the Cisco IOS router console environment.	

debug cellular messages dm

To print Diagnostics Monitor (DM) messages from the Qualcomm CDMA chipset, use the **debug cellular messages dm** command in EXEC mode.

debug cellular *slot/wic_slot/port* **messages dm**

Syntax Description	<i>slot/wic_slot/port</i>	Numeric values that indicate the router slot, WAN interface card (WIC) slot, and port.
---------------------------	---------------------------	--

Command Default There is no default for this command.

Command Modes EXEC

Command History	Release	Modification
	12.4(11)XV	This command was introduced.
	12.4(15)T	This command was integrated into Cisco IOS Release 12.4(15)T.

Usage Guidelines Use this command for debugging purposes only.

Related Commands	Command	Description
	debug cellular messages all	Prints all Cisco IOS driver debug messages.
	debug cellular messages async	Debugs cellular async.
	debug cellular messages data	Prints Cisco IOS data path debug messages.
	debug cellular driver	Debugs the Cisco IOS driver.
	debug cellular firmware	Displays Cisco IOS firmware information.
	debug cellular messages management	Prints management path messages, such as CnS.
	debug cellular messages virt-con	Redirects the Nios II console driver messages to display them in the Cisco IOS router console environment.

debug cellular messages management

To print management path messages, such as CnS, use the **debug cellular messages management** command in EXEC mode.

debug cellular *slot/wic_slot/port* **messages management**

Syntax Description	<i>slot/wic_slot/port</i>	Numeric values that indicate the router slot, WAN interface card (WIC) slot, and port.
---------------------------	---------------------------	--

Command Default	None
------------------------	------

Command Modes	EXEC
----------------------	------

Command History	Release	Modification
	12.4(11)XV	This command was introduced.
	12.4(15)T	This command was integrated into Cisco IOS Release 12.4(15)T.

Usage Guidelines	Use this command for debugging purposes only.
-------------------------	---

Related Commands	Command	Description
	debug cellular messages all	Prints all Cisco IOS driver debug messages.
	debug cellular messages async	Debugs cellular async.
	debug cellular messages data	Prints Cisco IOS data path debug messages.
	debug cellular driver	Debugs the Cisco IOS driver.
	debug cellular firmware	Displays Cisco IOS firmware information.
	debug cellular messages virt-con	Redirects the Nios II console driver messages to display them in the Cisco IOS router console environment.

debug cellular messages virt-con

To redirect the Nios II console driver messages to display them in the Cisco IOS router console environment, use the **debug cellular virt-con** command in EXEC mode.

```
debug cellular slot/wic_slot/port virt-con { clear | disable | dump-data-structs | log | monitor | wrapper-on | wrapper-off }
```

Syntax	Description
<i>slot/wic_slot/port</i>	Numeric values that indicate the router slot, WAN interface card (WIC) slot, and port.
clear	(Optional) Clears all virtual console debug log messages.
disable	(Optional) Disables virtual console real-time debug monitoring.
dump-data-structs	(Optional) Dumps virtual console data structures.
log	(Optional) Displays virtual console messages from the debug log.
monitor	(Optional) Enables monitoring of real-time virtual console debug messages.
wrapper-on	(Optional) Disables wraparound for virtual console log messages.
wrapper-off	(Optional) Enables wraparound for virtual console log messages.

Command Default There is no default for this command.

Command Modes EXEC

Command History	Release	Modification
	12.4(11)XV	This command was introduced.
	12.4(15)T	This command was integrated into Cisco IOS Release 12.4(15)T.

Usage Guidelines Use this command for debugging purposes only.

Related Commands	Command	Description
	debug cellular messages all	Prints all Cisco IOS driver debug messages.
	debug cellular messages async	Debugs cellular async.
	debug cellular messages data	Prints Cisco IOS data path debug messages.
	debug cellular driver	Debugs the Cisco IOS driver.
	debug cellular firmware	Displays Cisco IOS firmware information.
	debug cellular messages management	Prints management path messages, such as CnS.
	debug cellular messages dm	Prints diagnostics monitor (DM) messages from the Qualcomm CDMA chipset.

show cellular all

To display all the modem information in one listing, use the **show cellular all** command in privileged EXEC mode.

show cellular *slot/wic_slot/port* **all**

Syntax Description	<i>slot/wic_slot/port</i>	Numeric values that indicate the router slot, WAN interface card (WIC) slot, and port.
---------------------------	---------------------------	--

Command Default	None
------------------------	------

Command Modes	Privileged EXEC
----------------------	-----------------

Command History	Release	Modification
	12.4(11)XV	This command was introduced.
	12.4(15)T	This command was integrated into Cisco IOS Release 12.4(15)T.

Usage Guidelines	The command usage is the same for Global System for Mobile Communications (GSM) and code division multiple access (CDMA), although the output is different for each.
-------------------------	--

Examples	<p>This section contains:</p> <ul style="list-style-type: none"> • Sample Output for 3G-HWIC-GSM • Sample Output for 3G-HWIC-CDMA
-----------------	---

Sample Output for 3G-HWIC-GSM

The following example shows output from the **show cellular all** command for slot 0, WIC slot 0, port 0:

```
router# show cellular 0/0/0 all

Hardware Information
=====
Modem Firmware Version = U1_2_22MCAP G:/WORK
Modem Firmware built = 04/17/06
Hardware Version = E2
International Mobile Subscriber Identity (IMSI) = 001012345678901
International Mobile Equipment Identity (IMEI) = 352678010002779
Factory Serial Number (FSN) = S2128751274E2OK
Modem Status = Online
Current Modem Temperature = 28 deg C, State = Normal

Profile Information
=====
Profile 1 = INACTIVE*
-----
```

```
PDP Type = IPv4, Header Compression = OFF
Data Compression = OFF
Access Point Name (APN) = vpn.com
Authentication = CHAP
Username: wapuser1, Password: wap

* - Default profile

Data Connection Information
=====
Data Transmitted = 0 bytes, Received = 0 bytes
Profile 1, Packet Session Status = INACTIVE
    Inactivity Reason = Normal inactivate state
Profile 2, Packet Session Status = INACTIVE
    Inactivity Reason = Normal inactivate state
Profile 3, Packet Session Status = INACTIVE
    Inactivity Reason = Normal inactivate state
Profile 4, Packet Session Status = INACTIVE
    Inactivity Reason = Normal inactivate state
Profile 5, Packet Session Status = INACTIVE
    Inactivity Reason = Normal inactivate state
Profile 6, Packet Session Status = INACTIVE
    Inactivity Reason = Normal inactivate state
Profile 7, Packet Session Status = INACTIVE
    Inactivity Reason = Normal inactivate state
Profile 8, Packet Session Status = INACTIVE
    Inactivity Reason = Normal inactivate state
Profile 9, Packet Session Status = INACTIVE
    Inactivity Reason = Normal inactivate state
Profile 10, Packet Session Status = INACTIVE
    Inactivity Reason = Normal inactivate state
router#
Network Information
=====
Current Service Status = No service, Service Error = None
Current Service = Invalid
Packet Service = None
Packet Session Status = Inactive
Current Roaming Status = Home
Network Selection Mode = Automatic
Country = 0, Network =
Mobile Country Code (MCC) = 0
Mobile Network Code (MNC) = 0
Location Area Code (LAC) = 0
Routing Area Code (RAC) = 255
Cell ID = 0
Primary Scrambling Code = 0
PLMN Selection = Automatic

Radio Information
=====
Current Band = None, Channel Number = 0
Current RSSI = -110 dBm

Modem Security Information
=====
Card Holder Verification (CHV1) = Disabled
SIM Status = OK
SIM User Operation Required = None
Number of Retries remaining = 3
router#
```

Sample Output for 3G-HWIC-CDMA

The following example shows the output from the **show cellular all** command for slot 0, WIC slot 3, port 0:

```

router# show cellular 0/0/0 all

Hardware Information
=====
Modem Firmware Version = p2005600
Modem Firmware built = 11-14-06
Hardware Version = 1.0
Electronic Serial Number (ESN) = 0x6032688F
Preferred Roaming List (PRL) Version = 20224
Current Modem Temperature = 32 degrees Celsius

Profile Information
=====
Electronic Serial Number (ESN) = 0x6032688F
Modem activated = YES

Account Information:
=====
Activation Date: Not available
Phone Number (MDN) : 9135938079
Mobile Station Identifier (MSID) : 9135938079

Data Profile Info:
=====
Number of data profiles configured : 2
Current active data profile : 1

Data Profile 0 Information
=====
NAI (Network Access Identifier) = 6032688F@hcm.sprintpcs.com
MN-HA SS = Set
MN-HA SPI = 1234
MN-AAA SS = Set
MN-AAA SPI = 1234
Reverse Tunneling Preference = Set
Home Address = 0.0.0.0
Primary Home Agent Address = 68.28.15.12
Secondary Home Agent Address = 68.28.31.12

Data Profile 1 Information (Active)
=====
NAI (Network Access Identifier) = productmarketing432@sprintpcs.com
MN-HA SS = Set
MN-HA SPI = 1234
MN-AAA SS = Set
MN-AAA SPI = 1234
Reverse Tunneling Preference = Set
Home Address = 0.0.0.0
Primary Home Agent Address = 68.28.81.76
Secondary Home Agent Address = 68.28.89.76

Data Connection Information
=====
Phone number of outgoing call =
HDR AT State = Idle, HDR Session State = Open
HDR Session Info:
    UATI (Hex) = 0084:0AC0:0000:0000:000A:05DC:A821:DCFC
    Color Code = 32, RATI = 0xFFFFFFFF

```

```

    Session duration = 0 msec, Session start = 0 msec
    Session end = 0 msec, Authentication Status = Not authenticated
HDR DRC Value = 11, DRC Cover = 0, RRI = Pilot only
Current Transmitted = 0 bytes, Received = 0 bytes
Total Transmitted = 0 KB, Received = 0 KB
Current Call Status = DISCONNECTED
Current Call Duration = 30 secs
Total Call Duration = 4482879 seconds
Current Call State =
Last Call Disconnect Reason = Base station release (No reason)
Last Connection Error = None
HDR DDTM (Data Dedicated Transmission Mode) Preference = Off
Mobile IP Error Code (RFC-2002) = 0 (Registration accepted)

```

Network Information

```

=====
Current Service = 1xEV-DO (Rev A) and 1xRTT
Current Roaming Status(1xRTT) = HOME, (HDR) = HOME
Current Idle Digital Mode = HDR
Current System Identifier (SID) = 4183
Current Network Identifier (NID) = 87
Current Call Setup Mode = Mobile IP only
Serving Base Station Longitude = 0 deg 0 min 0 sec
Serving Base Station Latitude = 0 deg 0 min 0 sec
Current System Time = Tue Feb 6 15:12:18 2007

```

Radio Information

```

=====
1xRTT related info
-----
Current RSSI = -94 dBm, ECIO = -8 dBm
Current Channel Number = 50
Current Channel State = Acquired
Current Band Class = Band Class 1

HDR (1xEVDO) related info
-----
Current RSSI = -83 dBm, ECIO = -0 dBm
Current Channel Number = 25
Current Band Class = Band Class 1
Sector ID (Hex) = 0084:0AC0:0000:0000:000A:05DC:A801:1202
Subnet Mask = 104, Color Code = 32, PN Offset = 240
Rx gain control(Main) = 0 dBm, Diversity = Unavailable
Tx total power = -2 dBm, Tx gain adjust = 1536 dBm
Carrier to interference (C/I) ratio = 7

```

Modem Security Information

```

=====
Modem PIN Security UNLOCKED
Power-up lock DISABLED
router#

```

Related Commands	Command	Description
	cellular cdma activate otasp	Activates a cellular account using the over the air service provisioning (OTASP).
	show cellular hardware	Displays the cellular modem hardware information.
	show cellular network	Displays the cellular network (base station) information.
	show cellular profile	Displays the cellular profile information.

■ show cellular all

Command	Description
show cellular radio	Displays the cellular modem radio statistics.
show cellular security	Displays the modem lock state.
show controllers cellular	Displays the SMS messages received by the cellular modem.

show cellular connection

To display the current active connection state and data statistics, use the **show cellular connection** command in privileged EXEC mode.

show cellular *slot/wic_slot/port* **connection**

Syntax Description	<i>slot/wic_slot/port</i>	Numeric values that indicate the router slot, WAN interface card (WIC) slot, and port.
---------------------------	---------------------------	--

Command Default	None
------------------------	------

Command Modes	Privileged EXEC
----------------------	-----------------

Command History	Release	Modification
	12.4(11)XV	This command was introduced.
	12.4(15)T	This command was integrated into Cisco IOS Release 12.4(15)T.

Usage Guidelines	The command usage is the same for Global System for Mobile Communications (GSM) and code division multiple access (CDMA), although the output is different for each.
-------------------------	--

Examples	<p>This section contains:</p> <ul style="list-style-type: none"> • Sample Output for 3G-HWIC-GSM • Sample Output for 3G-HWIC-CDMA
-----------------	---

Sample Output for 3G-HWIC-GSM

The following is sample output for slot 1, wic 0, port 1.

```
router# show cellular 1/0/1 connection
Data Transmitted = 1066807500 bytes, Received = 1066807500 bytes
Profile 1, Packet Session Status = ACTIVE
      IP address = 1.5.97.2
Profile 2, Packet Session Status = INACTIVE
      Inactivity Reason = Normal inactivate state
```

[Table 6](#) describes each output field.

Table 6 Output Description

Field	Description
Data Transmitted	Total data transmitted by the modem. Can be cleared by the clear counters command.
Data Received	Total data received by the modem. Can be cleared by the clear counters command.
Profile <profile number>	Indicates the profiles configured in the modem. A total of 16 profiles can be configured.
Packet Session Status	Packet Data Protocol (PDP) session status of the profile. Active when the call is made and PDP context has become active in the modem.
IP Address	IP address of the cellular interface received during IPCP negotiation.
Inactivity Reason	Reason why the profile is inactive.

Sample Output for 3G-HWIC-CDMA

The following example is sample output for slot 0, WIC slot 0, port 0 from the **show cellular connection** command:

```
router# show cellular 0/0/0 connection

Phone number of outgoing call =
HDR AT State = Idle, HDR Session State = Open
HDR Session Info:
  UATI (Hex) = 0084:0AC0:0000:0000:000A:05DC:A821:DCFC
  Color Code = 32, RATI = 0xFFFFFFFF
  Session duration = 0 msecs, Session start = 0 msecs
  Session end = 0 msecs, Authentication Status = Not authenticated
HDR DRC Value = 11, DRC Cover = 0, RRI = Pilot only
Current Transmitted = 0 bytes, Received = 0 bytes
Total Transmitted = 0 KB, Received = 0 KB
Current Call Status = DISCONNECTED
Current Call Duration = 30 secs
Total Call Duration = 4482879 seconds
Current Call State =
Last Call Disconnect Reason = Base station release (No reason)
Last Connection Error = None
HDR DDTM (Data Dedicated Transmission Mode) Preference = Off
Mobile IP Error Code (RFC-2002) = 0 (Registration accepted)
router#
```

[Table 7](#) describes each output field.

Table 7 Description of Sample Output for CDMA

Field	Description
Phone number of outgoing call	Shows the phone number of the data call dialed.
HDR AT State	Indicates the AT state. Will show as CONNECTED when the CONNECT is received from the modem while dialing out. This is valid only for 1xEVDO.

Table 7 Description of Sample Output for CDMA (continued)

Field	Description
HDR Session State	Will indicate as OPEN once the HDR session is established. This is valid only for 1xEVDO
UATI	Unicast Access Terminal Identifier (UATI) obtained by the modem or access terminal (AT) from the base station during session establishment.
Color Code	HDR session color code for the sector.
RATI	HDR Random Access Terminal Identifier used for opening a session.
Session Duration	HDR session duration in milliseconds.
Session Start	Phone uptime in units of milliseconds at session start.
Session End	Phone uptime in units of milliseconds at session end.
Authentication Status	Modem or access terminal authentication status with the base station.
HDR DRC Value	The data rate channel value specified by the access terminal. The access terminal uses DRC value to specify the requested transmission rate
DRC Cover	DRC cover value used by the access terminal to specify the transmitting sector.
RRI	Indicates the rate of the reverse traffic data channel.
Current Transmitted	Number of bytes transmitted by the modem to the base station. This will be cleared when the call is disconnected.
Current Received	Number of bytes received by the modem from the base station. This will be cleared when the call is disconnected.
Current call status	Current call status of the modem, such as CONNECTED, DISCONNECTED, DORMANT, CONNECTING, or ERROR.
Privacy Mode	Current privacy status of the call in progress.
Service Option	Service option for the call in progress.
Current Call Duration	Duration of the call in progress. A call status of DISCONNECTED displays the call duration of the last call.
Total Transmitted	Total number of kilobytes transmitted from the modem. This will be cleared by the clear counters command.
Total Received	Total number of kilobytes received by the modem. This will be cleared by the clear counters command.

Table 7 Description of Sample Output for CDMA (continued)

Field	Description
Total Call Duration	Total duration of calls made from the modem. This will be updated when the current call in progress is disconnected.
Current Call State	Indicates the type of call made.
Last Call Disconnect Reason	Indicates why the last call was disconnected.
Last Connection Error	Indicates the error code if the call status indicates an error.
Mobile IP Error Code	Indicates the error code in accordance with RFC-2002 if the call is a mobile IP call.

Related Commands

Command	Description
cellular cdma activate manual	Manually activates a cellular account using the over-the-air service (OTA) procedure.
show cellular hardware	Displays the cellular modem hardware information.
show cellular network	Displays the cellular network (base station) information.
show cellular profile	Displays the cellular profile information.
show cellular radio	Displays the cellular modem radio statistics.
show cellular security	Displays the modem lock state.
show controllers cellular	Displays HWIC hardware- and driver-specific information.

show cellular hardware

To display the cellular modem hardware information, use the **show cellular hardware** command in privileged EXEC mode.

show cellular *slot/wic_slot/port* hardware

Syntax Description	<i>slot/wic_slot/port</i>	Numeric values that indicate the router slot, WAN interface card (WIC) slot, and port.
---------------------------	---------------------------	--

Command Default	None
------------------------	------

Command Modes	Privileged EXEC
----------------------	-----------------

Command History	Release	Modification
	12.4(11)XV	This command was introduced.
12.4(15)T	This command was integrated into Cisco IOS Release 12.4(15)T.	

Usage Guidelines	The command usage is the same for Global System for Mobile Communications (GSM) and code division multiple access (CDMA), although the output is different for each.
-------------------------	--

Examples	<p>This section contains:</p> <ul style="list-style-type: none"> • Sample Output for HWIC-3G-GSM • Sample Output for HWIC-3G-CDMA
-----------------	---

Sample Output for HWIC-3G-GSM

The following example shows output for slot 0, WIC slot 0, port 0:

```
router# show cellular 0/0/0 hardware

Modem Firmware Version = H1_0_0_1MCAP C:/WS/
Modem Firmware built = 09/08/06
Hardware Version = 1.0
International Mobile Subscriber Identity (IMSI) = <number>
International Mobile Equipment Identity (IMEI) = <number>
Factory Serial Number (FSN) = X2819460254100D
Modem Status = Online
Current Modem Temperature = 33 deg C, State = Normal
```

Table 8 Output Description for show cellular hardware command

Field	Description
Modem Firmware Version	Firmware version of the modem.
Modem Firmware Built	Date firmware was built in <i>mm-dd-yy</i> format.
Hardware Version	Modem hardware version.
International Mobile Subscriber Identity (IMSI)	IMSI is stored in the SIM. IMSI consists of MCC (mobile country code, 3 digits), MNC (mobile network code, 3 digits for N. America and 2 digits for rest of the world) and MSIN (mobile station identification number). The MCC and MNC in the IMSI identify the subscribers in the PLMN (Public Land Mobile Network).
International Mobile Equipment Identity (IMEI)	Number that uniquely identifies the modem in a GSM/UMTS network.
Factory Serial Number (FSN)	Unique serial number of the modem.
Modem Status	Will be online if the modem has booted up correctly; otherwise will be offline and the modem will not be usable.
Current Modem Temperature	Radio temperature of the modem in degrees Celsius. State is normal when temperature is between 5 to 185°F (-15° to 85°C). If state reaches critical 226.4°F (108°C), the modem will be shutdown.

Sample Output for HWIC-3G-CDMA

The following example shows output for slot 0, WIC slot 0, port 0:

```
router# show cellular 0/0/0 hardware

Modem Firmware Version = p2005600
Modem Firmware built = 11-14-06
Hardware Version = 1.0
Electronic Serial Number (ESN) = 0x6032688F
Preferred Roaming List (PRL) Version = 20224
Current Modem Temperature = 32 degrees Celsius
```

Table 9 describes each output field.

Table 9 Output Description for show cellular hardware command

Field	Description
Modem Firmware Version	Firmware version of the modem.
Modem Firmware Built	Date firmware was built in <i>mm-dd-yy</i> format.
Hardware Version	Modem hardware version.
Electronic Serial Number	Unique serial number of the modem.

Table 9 *Output Description for show cellular hardware command (continued)*

Field	Description
Preferred Roaming List (PRL) Version	PRL version is unique to a service provider. This indicates to the modem which channels the modem should scan.
Current Modem Temperature	Radio temperature of the modem in degrees Celsius.

Related Commands

Command	Description
show cellular radio	Displays the cellular modem radio statistics.
show cellular security	Displays the modem lock state.
show controllers cellular	Displays HWIC hardware- and driver-specific information.

show cellular network

To display information about the carrier network and service, use the **show cellular network** command in privileged EXEC mode.

show cellular *slot/wic_slot/port* network

Syntax Description	<i>slot/wic_slot/port</i>	Numeric values that indicate the router slot, WAN interface card (WIC) slot, and port.
---------------------------	---------------------------	--

Command Default	None
------------------------	------

Command Modes	Privileged EXEC
----------------------	-----------------

Command History	Release	Modification
	12.4(11)XV	This command was introduced.
12.4(15)T	This command was integrated into Cisco IOS Release 12.4(15)T.	

Usage Guidelines	The command usage is the same for Global System for Mobile Communications (GSM) and code division multiple access (CDMA), although the outputs differ.
-------------------------	--

Examples	<p>This section contains:</p> <ul style="list-style-type: none"> • Sample Output for HWIC-3G-GSM • Sample Output for HWIC-3G-CDMA
-----------------	---

Sample Output for HWIC-3G-GSM

The following example shows output for HWIC-3G-GSM in slot 0, WIC slot 0, port 0:

```
router# show cellular 0/0/0 network
Current Service Status = Normal, Service Error = None
Current Service = Combined
Packet Service = UMTS/WCDMA (Attached)
Packet Session Status = Inactive
Current Roaming Status = Roaming
Network Selection Mode = Automatic
Country = USA, Network = CINGULAR
Mobile Country Code (MCC) = 310
Mobile Network Code (MNC) = 380
Location Area Code (LAC) = 56997
Routing Area Code (RAC) = 253
Cell ID = 4503
Primary Scrambling Code = 169
PLMN Selection = Automatic
Registered PLMN = Cingular , Abbreviated =
Service Provider =
```

Table 10 describes each output field.

Table 10 Output Description for show cellular hardware command for GSM

Field	Description
Current Service Status	Indicates whether service is available.
Current Service Error	Shows the error in case there is no service
Current Idle Digital Mode	Idle mode of the modem.
Packet Service	Indicates the type of service available. For normal operation, the modem should be attached.
Packet Session Status	Status of PDP session. When data transfer is taking place, packet session will be active.
Current Roaming Status	Indicates whether the modem is in the home network or is roaming.
Network Selection Mode	Can be manual selection mode or automatic selection mode. Set to automatic by default.
Country	Country string given by the base station.
Network	Network string given by the base station.
Mobile Country Code	Country code given by the base station. The modem will be in the home network only if the country code given by the base station matches the MCC of the IMSI and the network code given by the base station matches the MNC of the IMSI.
Mobile Network Code	Network code given by the base station. The modem will be in the home network only if the country code given by the base station matches the MCC of the IMSI and the network code given by the base station matches the MNC of the IMSI.
Location Area Code	LAC given by the base station.
Routing Area Code	RAC given by the base station.
Cell ID	Cell ID given by the base station.
PLMN Selection	Default is automatic.

Sample Output for HWIC-3G-CDMA

The following example shows output for slot 0, WIC slot 0, port 0:

```
router# show cellular 0/0/0 network

Current Service = 1xEV-DO (Rev A) and 1xRTT
Current Roaming Status(1xRTT) = HOME, (HDR) = HOME
Current Idle Digital Mode = HDR
Current System Identifier (SID) = 4183
Current Network Identifier (NID) = 87
Current Call Setup Mode = Mobile IP only
Serving Base Station Longitude = 0 deg 0 min 0 sec
Serving Base Station Latitude = 0 deg 0 min 0 sec
Current System Time = Tue Feb 6 15:16:9 2007
```

Table 11 *Output Description for show cellular hardware command for CDMA*

Field	Description
Current Service	Service attached by the modem.
Current Roaming Status	Indicates whether the modem is in the home network or roaming.
Current Idle Digital Mode	Idle mode of the modem.
Current System Identifier	SID received by the modem (applicable only for 1xRTT).
Current Network Identifier	NID received by the modem (applicable only for 1xRTT).
Current BSS Longitude/Latitude	Geographic location of the BSS (if this information is received from the BSS).
Current System Time	System time received from the base station.

Related Commands

Command	Description
show cellular radio	Displays the cellular modem radio statistics.
show cellular security	Displays the modem lock state.
show controllers cellular	Displays HWIC hardware and driver-specific information.

show cellular profile

To display the cellular profile information, use the **show cellular profile** command in privileged EXEC mode.

show cellular *slot/wic_slot/port* **profile**

Syntax Description	<i>slot/wic_slot/port</i>	Numeric values that indicate the router slot, WAN interface card (WIC) slot, and port.
---------------------------	---------------------------	--

Command Default	None
------------------------	------

Command Modes	Privileged EXEC
----------------------	-----------------

Command History	Release	Modification
	12.4(11)XV	This command was introduced.
12.4(15)T	This command was integrated into Cisco IOS Release 12.4(15)T.	

Usage Guidelines	The command usage is the same for Global System for Mobile Communications (GSM) and code division multiple access (CDMA), although the output is different for each.
-------------------------	--

Examples	<p>This section contains:</p> <ul style="list-style-type: none"> • Sample Output for HWIC-3G-GSM • Sample Output for HWIC-3G-CDMA
-----------------	---

Sample Output for HWIC-3G-GSM

The following example shows output for HWIC-3G-GSM for slot 0, WIC slot 1, port 1:

```
router# show cellular 0/1/1 profile

Profile 1 = ACTIVE
-----
PDP Type = IPv4, Header Compression = ON
Data Compression = ON
PDP address = 0x7F000201
Access Point Name (APN) = enzo.cisco.com
Authentication = CHAP
Username: cisco, Password: lab
Primary DNS address = 127.0.2.1
Source Address = 127.0.2.1 255.255.255.0

Profile 2 = INACTIVE
-----
PDP Type = IPv4, Header Compression = ON
Data Compression = ON
```

```

PDP address = 0x7F000202
Access Point Name (APN) = enzo.cingular.com
Authentication = CHAP
Username: cisco, Password: lab
Primary DNS address = 127.0.2.1
Source Address = 127.0.2.2 255.255.255.0

```

Table 12 Field Descriptions for show cellular profile command

Field	Description
Profile <number>	Shows whether a particular profile is ACTIVE or INACTIVE. The profile is ACTIVE when the PDP context is active. This happens when a data call is successfully established.
PDP Type	Indicates the packet data protocol (PDP) type. Supported type is IPv4.
PDP Address	Shows the IP address assigned for the PDP context during PPP negotiation.
Access Point Name	Access Point Name for the profile. This information is provided by the service provider.
Authentication	PPP authentication supported. CHAP and PAP are supported. The type of authentication to be used is provided by the service provider.
Username	Username to be used for PPP authentication. This information is provided by the service provider.
Password	Password to be used for PPP authentication. This information is provided by the service provider.

Sample Output for HWIC-3G-CDMA

The following example shows output for HWIC-3G-CDMA for slot 0, WIC slot 1, port 1:

```

router# show cellular 0/0/0 profile

Electronic Serial Number (ESN) = 0x6032688F
Modem activated = YES

Account Information:
=====
Activation Date: Not available
Phone Number (MDN) : 1234567890
Mobile Station Identifier (MSID) : 1234567890

Data Profile Info:
=====
Number of data profiles configured : 2
Current active data profile : 1

Data Profile 0 Information
=====
NAI (Network Access Identifier) = 6032688F@hcm.sprintpcs.com
MN-HA SS = Set
MN-HA SPI = 1234
MN-AAA SS = Set
MN-AAA SPI = 1234
Reverse Tunneling Preference = Set
Home Address = 0.0.0.0

```

```

Primary Home Agent Address = 68.28.15.12
Secondary Home Agent Address = 68.28.31.12

Data Profile 1 Information (Active)
=====
NAI (Network Access Identifier) = productmarketing432@sprintpcs.com
MN-HA SS = Set
MN-HA SPI = 1234
MN-AAA SS = Set
MN-AAA SPI = 1234
Reverse Tunneling Preference = Set
Home Address = 0.0.0.0
Primary Home Agent Address = 68.28.81.76
Secondary Home Agent Address = 68.28.89.76

```

“*” Indicates the default profile.

Table 13 describes the output fields from the command.

Table 13 Field Description

Field	Description
Electronic Serial Number	A unique serial number for the CDMA modem.
Modem Activated	Indicates the activation status of the modem. Yes indicates that the modem is activated on the carrier network.
Data Profile	A data profile consists of the mobile IP (MIP) settings for the data connection. These settings are populated on the modem by the network using OTASP/IOTA.
ProvDate	Date the modem was provisioned, in yyyy/mm/dd format.
MDN	Mobile Directory Number assigned to the modem by the carrier during provisioning.
MIN	Mobile Identity Number assigned to the modem by the carrier during provisioning

Related Commands

Command	Description
cellular cdma activate manual	Manually activates a cellular account using the over-the-air service (OTA) procedure.
cellular cdma activate otasp	Activates a cellular account using the over the air service provisioning (OTASP).
cellular cdma activate iota	Provisions data profile using Internet-based over-the-air provisioning (IOTA).
Note	IOTA is supported only with certain wireless service providers. Please check with your wireless service provider.

show cellular radio

To display the cellular modem radio statistics, use the **show cellular radio** command in user privileged EXEC mode.

show cellular *slot/wic_slot/port* **radio** [**history** <**all** | **per-hour** | **per-min** | **per-sec**>]

Syntax Description		
	<i>slot/wic_slot/port</i>	Numeric values that indicate the router slot, WAN interface card (WIC) slot, and port.
	history	Displays the RSSI history.
	all	Complete RSSI history.
	per-hour	Per-hour RSSI history.
	per-min	Per-minute RSSI history.
	per-sec	Per-second RSSI history.

Command Default None

Command Modes Privileged EXEC

Command History	Release	Modification
	12.4(11)XV	This command was introduced.
	12.4(15)T	This command was integrated into Cisco IOS Release 12.4(15)T.

Usage Guidelines The command usage is the same for Global System for Mobile Communications (GSM) and code division multiple access (CDMA), although the output is different for each.

Examples This section contains:

- [Sample Output for HWIC-3G-GSM](#)
- [Sample Output for HWIC-3G-CDMA](#)

Sample Output for HWIC-3G-GSM

The following example shows output for HWIC-3G-GSM in slot 0, WIC slot 0, port 0:

```
router# show cellular 0/0/0 radio
```

```
Current Band = WCDMA 1900, Channel Number = 9721
Current RSSI (RSCP) = -91 dBm
```

Table 14 Output Description for show cellular radio command for GSM

Field	Description
Current Band	GPRS/UMTS band to which the modem is attached.
Channel Number	Channel number to which the modem is attached.
Current RSSI	Current radio signal strength on the modem. (-125 dbm indicates no signal.)

Sample Output for HWIC-3G-CDMA

The following example shows output for HWIC-3G-CDMA in slot 0, WIC slot 0, port 0:

```
router#show cellular 0/0/0 radio
1xRTT related info
-----
Current RSSI = -95 dBm, ECIO = -6 dBm
Current Channel Number = 50
Current Channel State = Acquired
Current Band Class = Band Class 1

HDR (1xEVDO) related info
-----
Current RSSI = -88 dBm, ECIO = -2 dBm
Current Channel Number = 25
Current Band Class = Band Class 1
Sector ID (Hex) = 0084:0AC0:0000:0000:000A:05DC:A801:1202
Subnet Mask = 104, Color Code = 32, PN Offset = 240
Rx gain control(Main) = 0 dBm, Diversity = Unavailable
Tx total power = -2 dBm, Tx gain adjust = 1536 dBm
Carrier to interference (C/I) ratio = 2
```

Table 15 Output Description for show cellular radio command for HWIC-3G-CDMA

Field	Description
Current RSSI	Current radio signal strength in dbm (-125 dbm indicates no signal).
Current ECIO	Current energy per chip (ECIO) in dbm.
Current Channel Number	Current channel number to which the modem is attached to the base station.
Current Channel State	Indicates whether the modem is scanning or has acquired the channel.
Current Band Class	Current band class that the modem is attached to.
Sector ID	Sector ID of the base station to which the modem is attached.
Subnet Mask	Subnet mask of the sector.
Color Code	Color code of the sector.
PN Offset	PN offset for the sector.
Rx Gain Control	Received gain control for the modem.
Tx Total Power	Transmitted power.

■ show cellular radio

Related Commands	Command	Description
	show cellular all	Displays the consolidated information about the modem.
	show controllers cellular	Displays HWIC-hardware and driver-specific information.

show cellular security

To display the SIM status (only for HWIC-3G-GSM) and modem lock state, use the **show cellular security** command in privileged EXEC mode.

show cellular *slot/wic_slot/port security*

Syntax Description	<i>slot/wic_slot/port</i>	Numeric values that indicate the router slot, WAN interface card (WIC) slot, and port.
---------------------------	---------------------------	--

Command Default	None
------------------------	------

Command Modes	Privileged EXEC
----------------------	-----------------

Command History	Release	Modification
	12.4(11)XV	This command was introduced.
	12.4(15)T	This command was integrated into Cisco IOS Release 12.4(15)T.

Usage Guidelines	The command usage is the same for Global System for Mobile Communications (GSM) and code division multiple access (CDMA), although the output is different for each.
-------------------------	--

Examples	<p>This section contains:</p> <ul style="list-style-type: none"> • Sample Output for HWIC-3G-GSM • Sample Output for HWIC-3G-CDMA
-----------------	---

Sample Output for HWIC-3G-GSM

The following example shows output for an HWIC-3G-GSM in slot 0, WIC slot 0, port 0:

```
router# show cellular 0/0/0 security
Card Holder Verification (CHV1) ENABLED
SIM Status = OK
SIM User Operation Required = CHV1
Number of Retries remaining = 3
```

[Table 16](#) describes the output from this command:

Table 16 Output Description

Filed	Description
Card Holder Verification	If enabled, access to the SIM is restricted.
SIM Status	Indicates whether the SIM is present or removed from the SIM socket.

Table 16 *Output Description (continued)*

Field	Description
SIM User Operation Required	If the SIM is protected (for example, because of CHV1 enabled), it will indicate the type of user operation required.
Number of Retries Remaining	Indicates the number of attempts remaining in case the SIM is locked. If the number of retries becomes zero, the SIM is blocked and becomes unusable.

Sample Output for HWIC-3G-CDMA

The following example shows output for an HWIC-3G-CDMA in slot 0, WIC slot 0, port 0:

```
router# show cellular 0/0/0 security
Modem PIN Security UNLOCKED
Power-up lock DISABLED
```

[Table 17](#) describes the output for this command.

Table 17 *Output Description*

Field	Description
Modem PIN Security	If the modem is locked, you cannot make calls without unlocking.
Power-up Lock	Shows whether the modem will be locked on power-up.

Related Commands

Command	Description
show cellular all	Displays the consolidated information about the modem.

show controllers cellular

To display high-speed WAN interface card (HWIC) hardware and driver-specific information, use the **show controllers cellular** command in privilege EXEC mode.

show controllers cellular *slot/wic_slot/port*

Syntax Description	<i>slot/wic_slot/port</i>	Numeric values that indicate the router slot, WAN interface card (WIC) slot, and port.
---------------------------	---------------------------	--

Command Default There is no default for this command.

Command Modes Privilege EXEC

Command History	Release	Modification
	12.4(11)XV	This command was introduced.
	12.4(15)T	This command was integrated into Cisco IOS Release 12.4(15)T.

Usage Guidelines Use this command to capture the output for debugging or troubleshooting purposes only.

Related Commands	Command	Description
	show interfaces cellular	Displays statistics for the cellular interfaces.
	show run interface cellular	Displays the current running configuration for the cellular interface.

show interfaces cellular

To display statistics for the cellular interface, use the **show interfaces cellular** command in EXEC mode.

show interfaces cellular *slot/wic_slot/port*

Syntax Description	<i>slot/wic_slot/port</i>	Numeric values that indicate the router slot, WAN interface card (WIC) slot, and port.
---------------------------	---------------------------	--

Command Default There is no default for this command.

Command Modes EXEC

Command History	Release	Modification
	12.4(11)XV	This command was introduced.
	12.4(15)T	This command was integrated into Cisco IOS Release 12.4(15)T.

Usage Guidelines When you enter this command, encapsulation should be PPP and all signals, such as DCD, DSR, DTR, RTS, and CTS, should be up during normal operation.

Examples This section contains:

- [Sample Output for 3G-HWIC-GSM](#)
- [Sample Output for 3G-HWIC-CDMA](#)

Sample Output for HWIC-3G-GSM

The following example shows the cellular interface statistics for HWIC-3G-GSM in slot 0, WIC slot 0, port 0 for GSM:

```
router#
router# show interfaces cellular 0/0/0
Cellular0/0/0 is up, line protocol is up
  Hardware is HSDPA/UMTS/EDGE/GPRS-850/900/1800/1900/2100MHz
  Internet address is 1.5.97.2/32
  MTU 1500 bytes, BW 384 Kbit, RxBW 2400000 Kbit, DLY 100000 usec,
    reliability 255/255, txload 1/255, rxload 1/255
  Encapsulation PPP, LCP Open
  Open: IPCP, loopback not set
  Keepalive not set
  Time to interface disconnect: idle 3w3d
  Last input 00:20:21, output 00:20:21, output hang never
  Last clearing of "show interface" counters 00:00:01
  Input queue: 1/75/0/0 (size/max/drops/flushes); Total output drops: 0
  Queueing strategy: weighted fair
  Output queue: 0/1000/64/0 (size/max total/threshold/drops)
```

```

Conversations 0/16/16 (active/max active/max total)
Reserved Conversations 0/0 (allocated/max allocated)
Available Bandwidth 288 kilobits/sec
30 second input rate 0 bits/sec, 0 packets/sec
30 second output rate 0 bits/sec, 0 packets/sec
0 packets input, 0 bytes, 0 no buffer
Received 0 b
*Feb 7 22:55:33.985: %CLEAR-5-COUNTERS: Clear counter on all interfaces by
consoleroadcasts, 0 runts, 0 giants, 0 throttles
0 input errors, 0 CRC, 0 frame, 0 overrun, 0 ignored, 0 abort
0 packets output, 0 bytes, 0 underruns
0 output errors, 0 collisions, 0 interface resets
0 output buffer failures, 0 output buffers swapped out
0 carrier transitions
DCD=up DSR=up DTR=up RTS=up CTS=up

```

Sample Output for HWIC-3G-CDMA

The following example shows the output for an HWIC-3G-CDMA in slot 0, WIC slot 0, port 0 for the **show interfaces cellular** command.

```

router# show int cellular 0/0/0
Cellular0/0/0 is up (spoofing), line protocol is up (spoofing)
Hardware is EVDO Rev A/Rel 0/1xRTT-800/1900MHz / SP
Internet address will be negotiated using IPCP
MTU 1500 bytes, BW 9 Kbit, DLY 100000 usec,
reliability 255/255, txload 1/255, rxload 1/255
Encapsulation PPP, LCP Closed, loopback not set
Keepalive not set
Last input never, output never, output hang never
Last clearing of "show interface" counters never
Input queue: 0/75/0/0 (size/max/drops/flushes); Total output drops: 0
Queueing strategy: weighted fair
Output queue: 0/1000/64/0 (size/max total/threshold/drops)
Conversations 0/0/16 (active/max active/max total)
Reserved Conversations 0/0 (allocated/max allocated)
Available Bandwidth 6 kilobits/sec
30 second input rate 0 bits/sec, 0 packets/sec
30 second output rate 0 bits/sec, 0 packets/sec
0 packets input, 0 bytes, 0 no buffer
Received 0 broadcasts, 0 runts, 0 giants, 0 throttles
0 input errors, 0 CRC, 0 frame, 0 overrun, 0 ignored, 0 abort
0 packets output, 0 bytes, 0 underruns
0 output errors, 0 collisions, 0 interface resets
0 output buffer failures, 0 output buffers swapped out
0 carrier transitions
DCD=up DSR=up DTR=up RTS=up CTS=up

```

Related Commands

Command	Description
show cellular radio	Displays the cellular modem radio statistics.
show controllers cellular	Displays HWIC hardware and driver-specific information.
show run interface cellular	Displays the current running configuration for the cellular interface.

show run interface cellular

To see the current running configuration for the cellular interface, use the **show run interface cellular** command in privileged EXEC mode.

show run interface cellular *slot/wic_slot/port*

Syntax Description	<i>slot/wic_slot/port</i>	Numeric values that indicate the router slot, WAN interface card (WIC) slot, and port.
---------------------------	---------------------------	--

Command Default There is no default for this command.

Command Modes Privileged EXEC

Command History	Release	Modification
	12.4(11)XV	This command was introduced.
	12.4(15)T	This command was integrated into Cisco IOS Release 12.4(15)T.

Examples The following example shows the output of the command for 3G HWIC in slot 0, WIC slot 0, port 0:

```
router#show running-config interface cellular 0/0/0
interface Cellular0/0/0
 ip address negotiated
 ip access-group 10 out
 ip nat outside
 ip virtual-reassembly
 encapsulation ppp
 no ip mroute-cache
 load-interval 30
 dialer in-band
 dialer idle-timeout 2147483
 dialer string cdma
 dialer-group 2
 async mode interactive
 no peer default ip address
 fair-queue
 ppp ipcp dns request
 routing dynamic
end router#
```

Related Commands	Command	Description
	show controllers cellular	Displays HWIC hardware and driver-specific information.
	show interfaces cellular	Displays statistics for the cellular interfaces.

Troubleshooting

This section provides the necessary background information and resources available for troubleshooting the Cisco 3G wireless HWIC.

Verifying Data Call Setup

To verify the data call setup, follow these steps:

-
- Step 1** After you create a modem data profile **cellular profile create** command and configuring DDR on the cellular interface, send a ping from the router to a host across the wireless network.
- Step 2** If the ping fails, debug the failure by using the following **debug** and **show** commands:
- **debug chat**
 - **debug dialer**
 - **debug ppp negotiation**
 - **show cellular all**
 - **show interface cellular**
 - **show running-config**
 - **show ip route**
- Step 3** Save the output from these commands and contact your system administrator.
-

Checking Signal Strength

If the Received Signal Strength Indication (RSSI) level is very low (for example, if it is less than -110 dBm) follow these steps:

-
- Step 1** Check the antenna connection. Make sure the TNC connector is correctly threaded and tightened.
- Step 2** If you are using a remote antenna, move the antenna cradle and check if the RSSI has improved.
- Step 3** Contact your wireless service provider to verify if there is service availability in your area.
-

Verifying Service Availability

The following is a sample output for the **show cellular all** command for a scenario where the antenna is disconnected and a modem data profile has not been created. The errors in this case have been highlighted with >>>>>>:

```
3825_GSM_3#show cellular 0/3/0 all
Load for five secs: 0%/0%; one minute: 0%; five minutes: 1%
```

Time source is hardware calendar, 19:40:43.239 UTC Wed Nov 8 2006

Hardware Information

```

=====
Modem Firmware Version = H1_0_0_7MCAP G:/WS/
Modem Firmware built = 10/26/06
Hardware Version = 1.0
International Mobile Subscriber Identity (IMSI) = <specific sim number>
International Mobile Equipment Identity (IMEI) = <specific modem number>
Factory Serial Number (FSN) = X2819460388100D
Modem Status = Online
Current Modem Temperature = 38 deg C, State = Normal

```

Profile Information

```

=====
* - Default profile >>>>>> no profile here.

```

Data Connection Information

```

=====

Profile 1, Packet Session Status = INACTIVE
    Inactivity Reason = Normal inactivate state
Profile 2, Packet Session Status = INACTIVE
    Inactivity Reason = Normal inactivate state
Profile 3, Packet Session Status = INACTIVE
    Inactivity Reason = Normal inactivate state
Profile 4, Packet Session Status = INACTIVE
    Inactivity Reason = Normal inactivate state
Profile 5, Packet Session Status = INACTIVE
    Inactivity Reason = Normal inactivate state
Profile 6, Packet Session Status = INACTIVE
    Inactivity Reason = Normal inactivate state
Profile 7, Packet Session Status = INACTIVE
    Inactivity Reason = Normal inactivate state
Profile 8, Packet Session Status = INACTIVE
    Inactivity Reason = Normal inactivate state
Profile 9, Packet Session Status = INACTIVE
    Inactivity Reason = Normal inactivate state
Profile 10, Packet Session Status = INACTIVE
    Inactivity Reason = Normal inactivate state
Profile 11, Packet Session Status = INACTIVE
    Inactivity Reason = Normal inactivate state
Profile 12, Packet Session Status = INACTIVE
    Inactivity Reason = Normal inactivate state
Profile 13, Packet Session Status = INACTIVE
    Inactivity Reason = Normal inactivate state
Profile 14, Packet Session Status = INACTIVE
    Inactivity Reason = Normal inactivate state
Profile 15, Packet Session Status = INACTIVE
    Inactivity Reason = Normal inactivate state
Profile 16, Packet Session Status = INACTIVE
    Inactivity Reason = Normal inactivate state

```

Network Information

```

=====
Current Service Status = No service, Service Error = None    >>>>>> no service means not
connected to the network.
Current Service = Combined
Packet Service = None
Packet Session Status = Inactive
Current Roaming Status = Home
Network Selection Mode = Automatic
Country = USA, Network = Cinglr

```

```

Mobile Country Code (MCC) = 310
Mobile Network Code (MNC) = 380
Location Area Code (LAC) = 6042
Routing Area Code (RAC) = 255
Cell ID = 0
Primary Scrambling Code = 0
PLMN Selection = Automatic

Radio Information
=====
Current Band = None, Channel Number = 0
Current RSSI = -110 dBm          >>>>>> either no antenna, or bad antenna or out of
network.

Modem Security Information
=====
Card Holder Verification (CHV1) = Disabled
SIM Status = OK
SIM User Operation Required = None
Number of Retries remaining = 3

```

Successful Call Setup

The following is a sample output when a call is set up using a CHAT script. It shows a received IP address from the network. Call setup is successful, and data path is open.

```

Debugs

debug modem
debug chat
debug ppp negotiation
debug ppp event
debug ppp error

3825_GSM_3#
Nov  8 20:04:42.295: CHAT0/3/0: Attempting async line dialer script
Nov  8 20:04:42.295: CHAT0/3/0: Dialing using Modem script: <carrier> & System script:
none
Nov  8 20:04:42.299: CHAT0/3/0: process started
Nov  8 20:04:42.299: CHAT0/3/0: Asserting DTR
Nov  8 20:04:42.299: CHAT0/3/0: Chat script <carrier> started          >>>>> chat script
invoked
Nov  8 20:04:42.299: CHAT0/3/0: Sending string: atdt*98*1#
Nov  8 20:04:42.299: CHAT0/3/0: Expecting string: CONNECT
Nov  8 20:04:42.343: CHAT0/3/0: Completed match for expect: CONNECT
Nov  8 20:04:42.343: CHAT0/3/0: Chat script <carrier> finished, status = Success >>>>
successful communication with modem
Nov  8 20:04:42.395: TTY0/3/0: no timer type 1 to destroy
Nov  8 20:04:42.395: TTY0/3/0: no timer type 0 to destroy
Nov  8 20:04:42.395: TTY0/3/0: no timer type 2 to destroy
Nov  8 20:04:44.395: %LINK-3-UPDOWN: Interface Cellular0/3/0, changed state to up
Nov  8 20:04:44.395: Ce0/3/0 PPP: Using dialer call direction
Nov  8 20:04:44.395: Ce0/3/0 PPP: Treating connection as a callout
Nov  8 20:04:44.395: Ce0/3/0 PPP: Session handle[7E000089] Session id[46]
Nov  8 20:04:44.395: Ce0/3/0 PPP: Phase is ESTABLISHING, Active Open
Nov  8 20:04:44.395: Ce0/3/0 PPP: No remote authentication for call-out
Nov  8 20:04:44.395: Ce0/3/0 LCP: O CONFREQ [Closed] id 75 len 16

```

```

Nov 8 20:04:44.395: Ce0/3/0 LCP: ACCM 0x000A0000 (0x0206000A0000)
Nov 8 20:04:44.395: Ce0/3/0 LCP: MagicNumber 0x179E8E46 (0x0506179E8E46)
Nov 8 20:04:44.395: Ce0/3/0 LCP: I CONFREQ [REQsent] id 83 len 25
Nov 8 20:04:44.395: Ce0/3/0 LCP: ACCM 0x00000000 (0x020600000000)
Nov 8 20:04:44.395: Ce0/3/0 LCP: AuthProto CHAP (0x0305C22305)
Nov 8 20:04:44.395: Ce0/3/0 LCP: MagicNumber 0x374C7C61 (0x0506374C7C61)
Nov 8 20:04:44.395: Ce0/3/0 LCP: PFC (0x0702)
Nov 8 20:04:44.395: Ce0/3/0 LCP: ACFC (0x0802)
Nov 8 20:04:44.395: Ce0/3/0 LCP: O CONFREQ [REQsent] id 83 len 8
Nov 8 20:04:44.395: Ce0/3/0 LCP: PFC (0x0702)
Nov 8 20:04:44.395: Ce0/3/0 LCP: ACFC (0x0802)
Nov 8 20:04:44.399: Ce0/3/0 LCP: I CONFACK [REQsent] id 75 len 16
Nov 8 20:04:44.399: Ce0/3/0 LCP: ACCM 0x000A0000 (0x0206000A0000)
Nov 8 20:04:44.399: Ce0/3/0 LCP: MagicNumber 0x179E8E46 (0x0506179E8E46)
Nov 8 20:04:44.399: Ce0/3/0 LCP: I CONFREQ [ACKrcvd] id 84 len 21
Nov 8 20:04:44.399: Ce0/3/0 LCP: ACCM 0x00000000 (0x020600000000)
Nov 8 20:04:44.399: Ce0/3/0 LCP: AuthProto CHAP (0x0305C22305)
Nov 8 20:04:44.399: Ce0/3/0 LCP: MagicNumber 0x374C7C61 (0x0506374C7C61)
Nov 8 20:04:44.399: Ce0/3/0 LCP: O CONFACK [ACKrcvd] id 84 len 21
Nov 8 20:04:44.399: Ce0/3/0 LCP: ACCM 0x00000000 (0x020600000000)
Nov 8 20:04:44.399: Ce0/3/0 LCP: AuthProto CHAP (0x0305C22305)
Nov 8 20:04:44.399: Ce0/3/0 LCP: MagicNumber 0x374C7C61 (0x0506374C7C61)
Nov 8 20:04:44.399: Ce0/3/0 LCP: State is Open
Nov 8 20:04:44.399: Ce0/3/0 PPP: Phase is AUTHENTICATING, by the peer
Nov 8 20:04:44.403: Ce0/3/0 CHAP: I CHALLENGE id 1 len 35 from "UMTS_CHAP_SRVR"
Nov 8 20:04:44.403: Ce0/3/0 CHAP: Using hostname from interface CHAP
Nov 8 20:04:44.403: Ce0/3/0 CHAP: Using password from interface CHAP
Nov 8 20:04:44.403: Ce0/3/0 CHAP: O RESPONSE id 1 len 40 from "<username configured on
the cellular interface>"
Nov 8 20:04:44.407: Ce0/3/0 CHAP: I SUCCESS id 1 len 4
Nov 8 20:04:44.407: Ce0/3/0 PPP: Phase is FORWARDING, Attempting Forward
Nov 8 20:04:44.407: Ce0/3/0 PPP: Phase is ESTABLISHING, Finish LCP
Nov 8 20:04:44.407: Ce0/3/0 PPP: Phase is UP

>>>> pap/chap succeeded

Nov 8 20:04:44.407: Ce0/3/0 IPCP: O CONFREQ [Closed] id 1 len 22
Nov 8 20:04:44.407: Ce0/3/0 IPCP: Address 0.0.0.0 (0x030600000000)
Nov 8 20:04:44.407: Ce0/3/0 IPCP: PrimaryDNS 0.0.0.0 (0x810600000000)
Nov 8 20:04:44.407: Ce0/3/0 IPCP: SecondaryDNS 0.0.0.0 (0x830600000000)
Nov 8 20:04:44.407: Ce0/3/0 PPP: Process pending ncp packets
Nov 8 20:04:45.411: Ce0/3/0 IPCP: I CONFNAK [REQsent] id 1 len 16
Nov 8 20:04:45.411: Ce0/3/0 IPCP: PrimaryDNS 10.11.12.13 (0x81060A0B0C0D)
Nov 8 20:04:45.411: Ce0/3/0 IPCP: SecondaryDNS 10.11.12.14 (0x83060A0B0C0E)
Nov 8 20:04:45.411: Ce0/3/0 IPCP: O CONFREQ [REQsent] id 2 len 22
Nov 8 20:04:45.411: Ce0/3/0 IPCP: Address 0.0.0.0 (0x030600000000)
Nov 8 20:04:45.411: Ce0/3/0 IPCP: PrimaryDNS 10.11.12.13 (0x81060A0B0C0D)
Nov 8 20:04:45.411: Ce0/3/0 IPCP: SecondaryDNS 10.11.12.14 (0x83060A0B0C0E)
Nov 8 20:04:45.459: Ce0/3/0 IPCP: I CONFREQ [REQsent] id 25 len 4
Nov 8 20:04:45.459: Ce0/3/0 IPCP: O CONFACK [REQsent] id 25 len 4
Nov 8 20:04:45.459: Ce0/3/0 IPCP: I CONFNAK [ACKsent] id 2 len 22
Nov 8 20:04:45.459: Ce0/3/0 IPCP: Address 166.138.186.119 (0x0306A68ABA77)
Nov 8 20:04:45.459: Ce0/3/0 IPCP: PrimaryDNS 66.102.163.231 (0x81064266A3E7)
Nov 8 20:04:45.459: Ce0/3/0 IPCP: SecondaryDNS 66.102.163.232 (0x83064266A3E8)
Nov 8 20:04:45.459: Ce0/3/0 IPCP: O CONFREQ [ACKsent] id 3 len 22
Nov 8 20:04:45.459: Ce0/3/0 IPCP: Address 166.138.186.119 (0x0306A68ABA77)
Nov 8 20:04:45.459: Ce0/3/0 IPCP: PrimaryDNS 66.102.163.231 (0x81064266A3E7)
Nov 8 20:04:45.459: Ce0/3/0 IPCP: SecondaryDNS 66.102.163.232 (0x83064266A3E8)
Nov 8 20:04:45.463: Ce0/3/0 IPCP: I CONFACK [ACKsent] id 3 len 22
Nov 8 20:04:45.463: Ce0/3/0 IPCP: Address 166.138.186.119 (0x0306A68ABA77)
Nov 8 20:04:45.463: Ce0/3/0 IPCP: PrimaryDNS 66.102.163.231 (0x81064266A3E7)
Nov 8 20:04:45.463: Ce0/3/0 IPCP: SecondaryDNS 66.102.163.232 (0x83064266A3E8)
Nov 8 20:04:45.463: Ce0/3/0 IPCP: State is Open
Nov 8 20:04:45.463: Ce0/3/0 IPCP: Install negotiated IP interface address 166.138.186.119

```

Modem Troubleshooting Using the Diagnostic Port

The RJ-45 port on the faceplate of the 3G wireless HWIC provides access to the debug port on the Sierra Wireless modem. By connecting an industry-standard diagnostic tool like Qualcomm CAIT/QXDM or Spirent UDM to this port, you can perform radio-level diagnostics and traffic monitoring on the modem. Use the following test command to turn diagnostics on:

```
router# test cell-hwic slot/port/wic dm-port on
```

The cable used to connect the PC/Laptop running the diagnostic tool is the standard Cisco router console cable (RJ-45 to DB-9).

**Note**

To enable test commands, you must enter the **service internal** command in the global configuration mode.

Any Internet Protocol (IP) addresses used in this document are not intended to be actual addresses. Any examples, command display output, and figures included in the document are shown for illustrative purposes only. Any use of actual IP addresses in illustrative content is unintentional and coincidental.

CCVP, the Cisco logo, and Welcome to the Human Network are trademarks of Cisco Systems, Inc.; Changing the Way We Work, Live, Play, and Learn is a service mark of Cisco Systems, Inc.; and Access Registrar, Aironet, Catalyst, CCDA, CCDP, CCIE, CCIP, CCNA, CCNP, CCSP, Cisco, the Cisco Certified Internetwork Expert logo, Cisco IOS, Cisco Press, Cisco Systems, Cisco Systems Capital, the Cisco Systems logo, Cisco Unity, Enterprise/Solver, EtherChannel, EtherFast, EtherSwitch, Fast Step, Follow Me Browsing, FormShare, GigaDrive, HomeLink, Internet Quotient, IOS, iPhone, IP/TV, iQ Expertise, the iQ logo, iQ Net Readiness Scorecard, iQuick Study, LightStream, Linksys, MeetingPlace, MGX, Networkers, Networking Academy, Network Registrar, PIX, ProConnect, ScriptShare, SMARTnet, StackWise, The Fastest Way to Increase Your Internet Quotient, and TransPath are registered trademarks of Cisco Systems, Inc. and/or its affiliates in the United States and certain other countries.

All other trademarks mentioned in this document or Website are the property of their respective owners. The use of the word partner does not imply a partnership relationship between Cisco and any other company. (0711R)

© 2007 Cisco Systems, Inc. All rights reserved.

